



南京大學

NANJING UNIVERSITY



Computer Networks

Wenzhong Li, Chen Tian

Nanjing University

Material with thanks to James F. Kurose, Mosharaf Chowdhury, and other colleagues.



Chapter 2. Direct Link Networks

- Link Service and Framing
- Error Detection and Reliable Transmission
- HDLC, PPP, and SONET
- Token Ring
- Ethernet
- Bridges and Layer-2 switch
- **Wireless Networks**
- Network Performance



Wireless and Mobile Networks



Wireless and Mobile Networks

- Extremely popular in the recent years
- Mobile users now exceeds wired phone users (>5:1)
- Two important challenges
 - **Wireless**: communication over wireless link
 - **Mobility**: handling the mobile user who changes point of attachment to network
 - Non-wireless networks may also have to deal with mobility issues
 - **Handoff**: Mobile changes base station providing connection into wired network



Elements of a wireless network

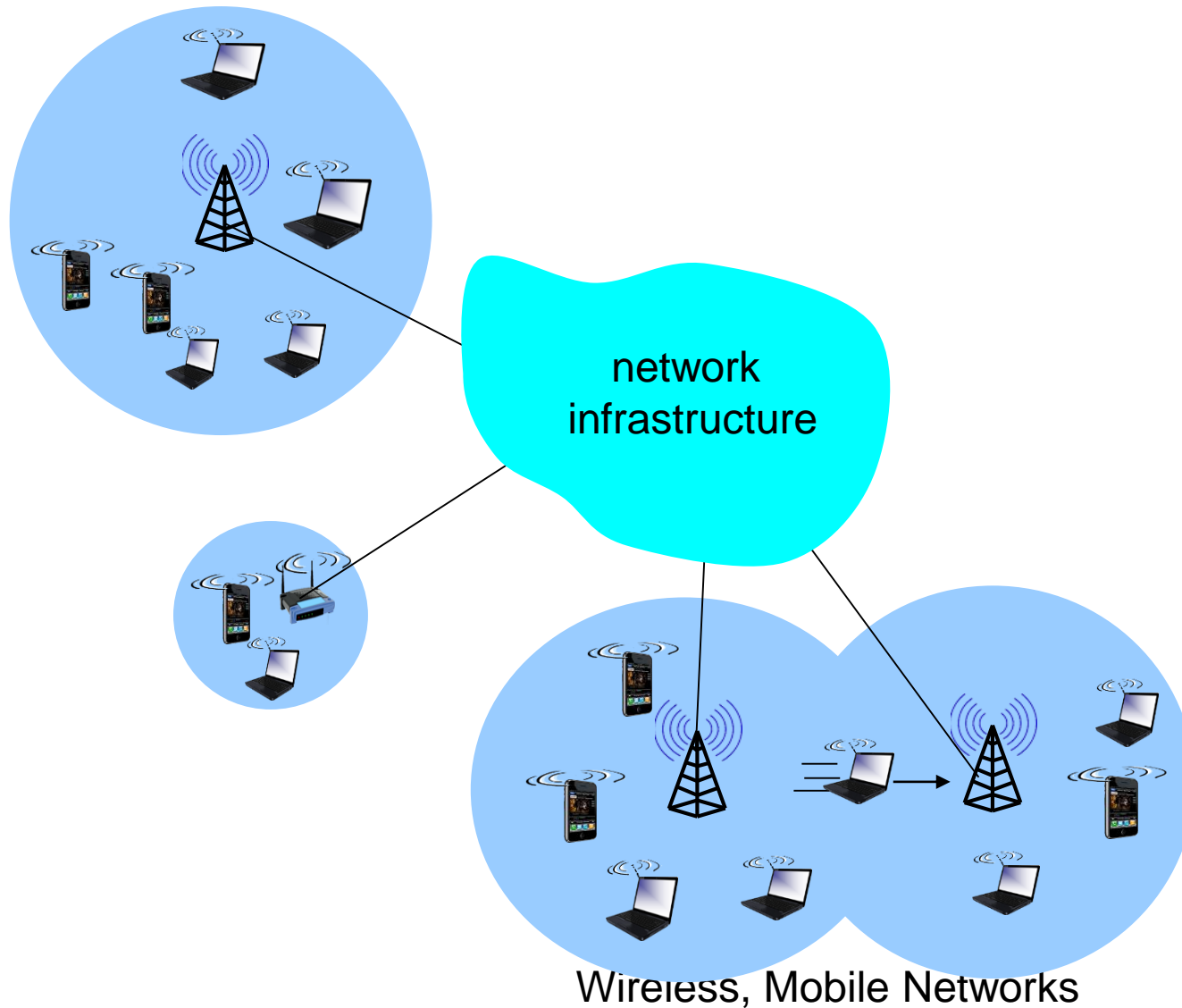



Elements of a wireless network

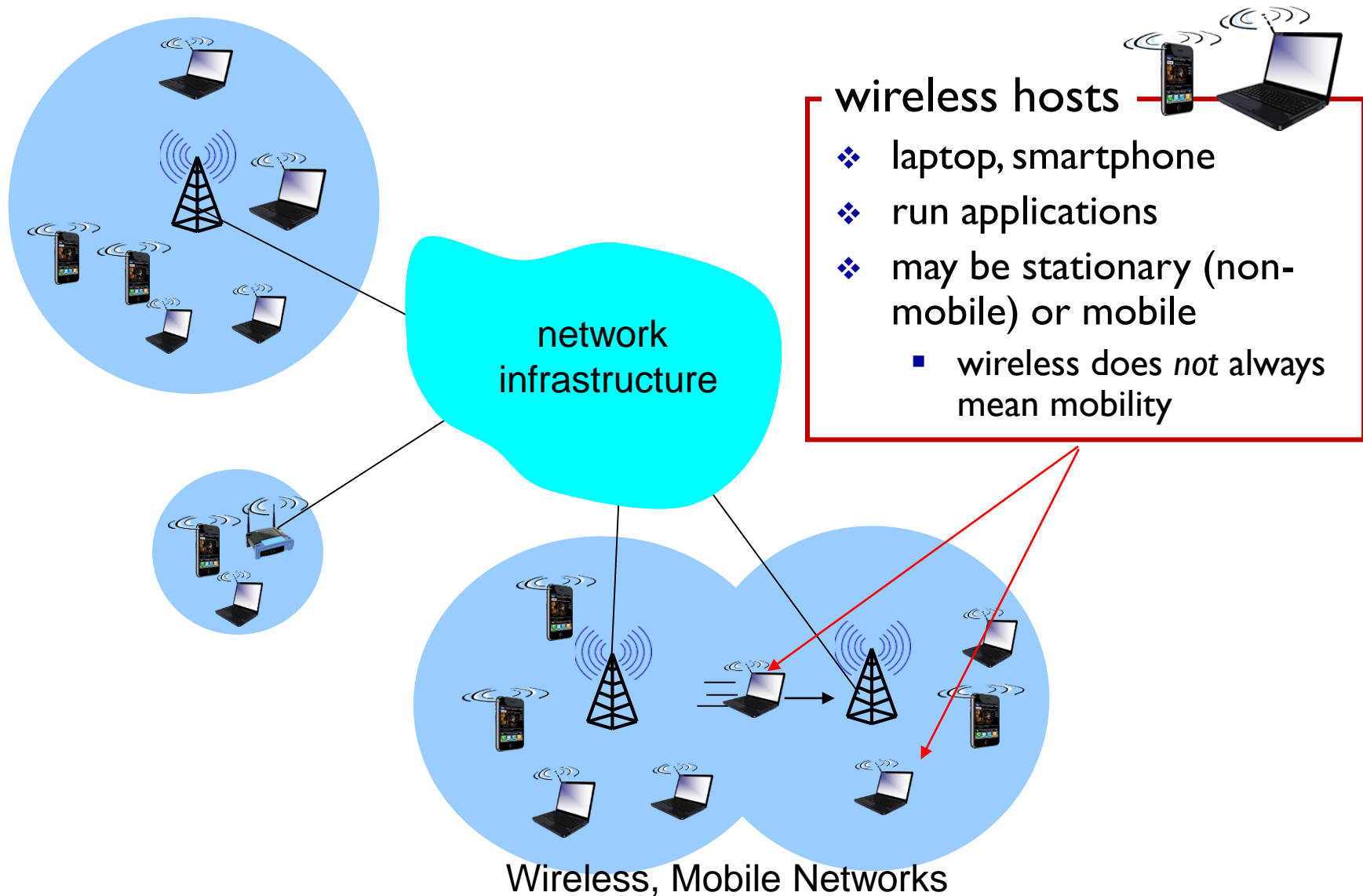



Elements of a wireless network

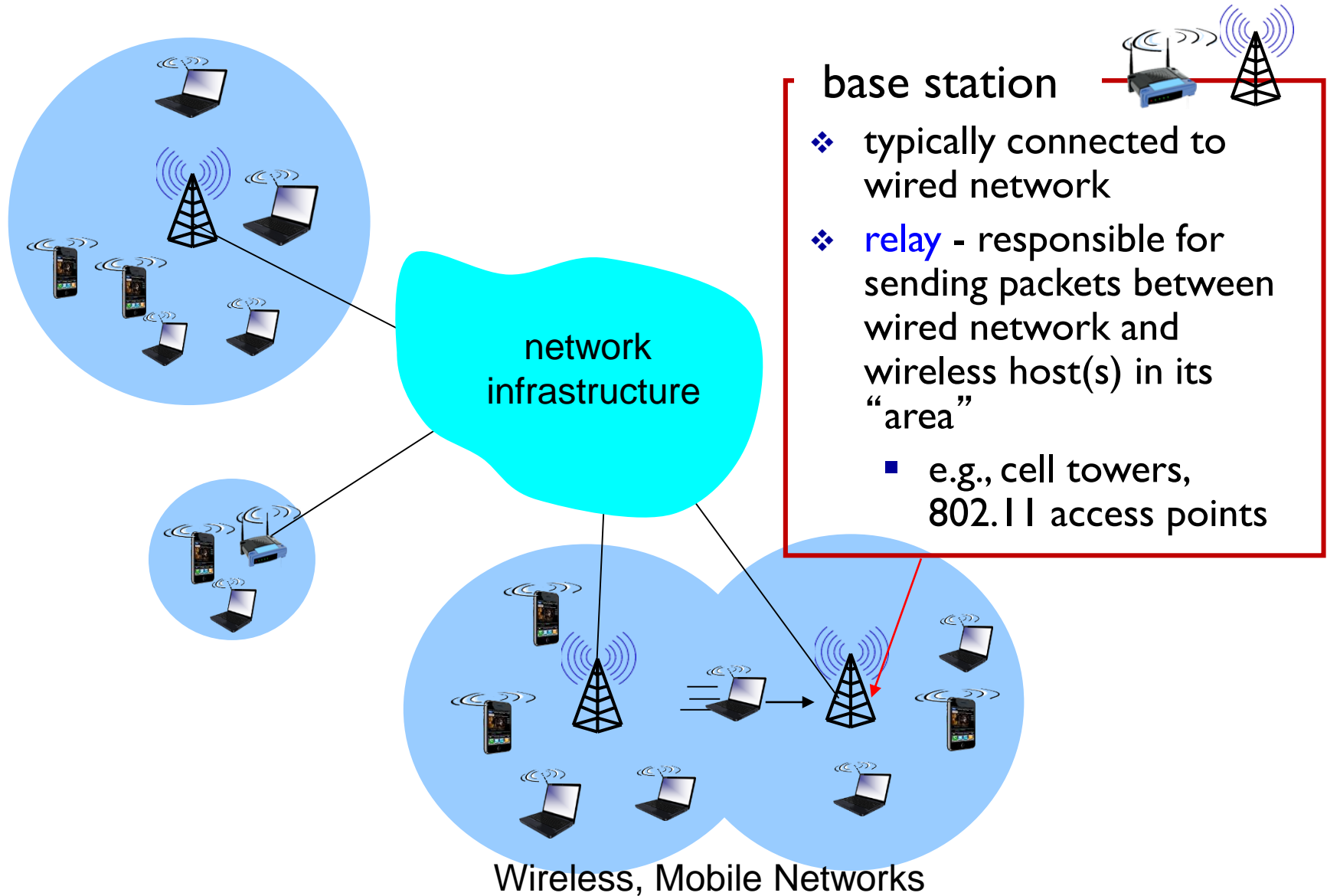



Elements of a wireless network

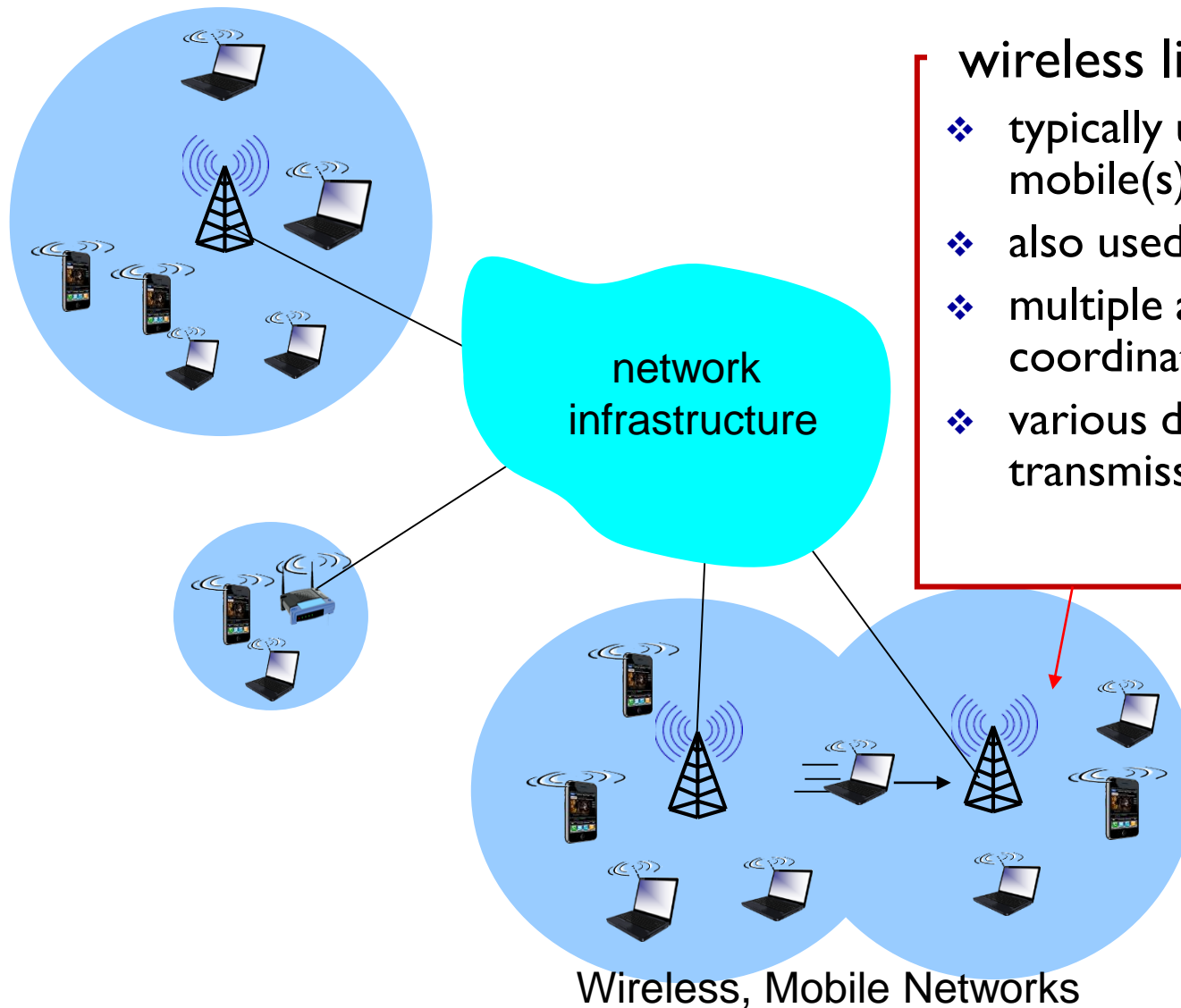

wireless link

- ❖ typically used to connect mobile(s) to base station
- ❖ also used as backbone link
- ❖ multiple access protocol coordinates link access
- ❖ various data rates, transmission distance



Various Wireless Link Standards

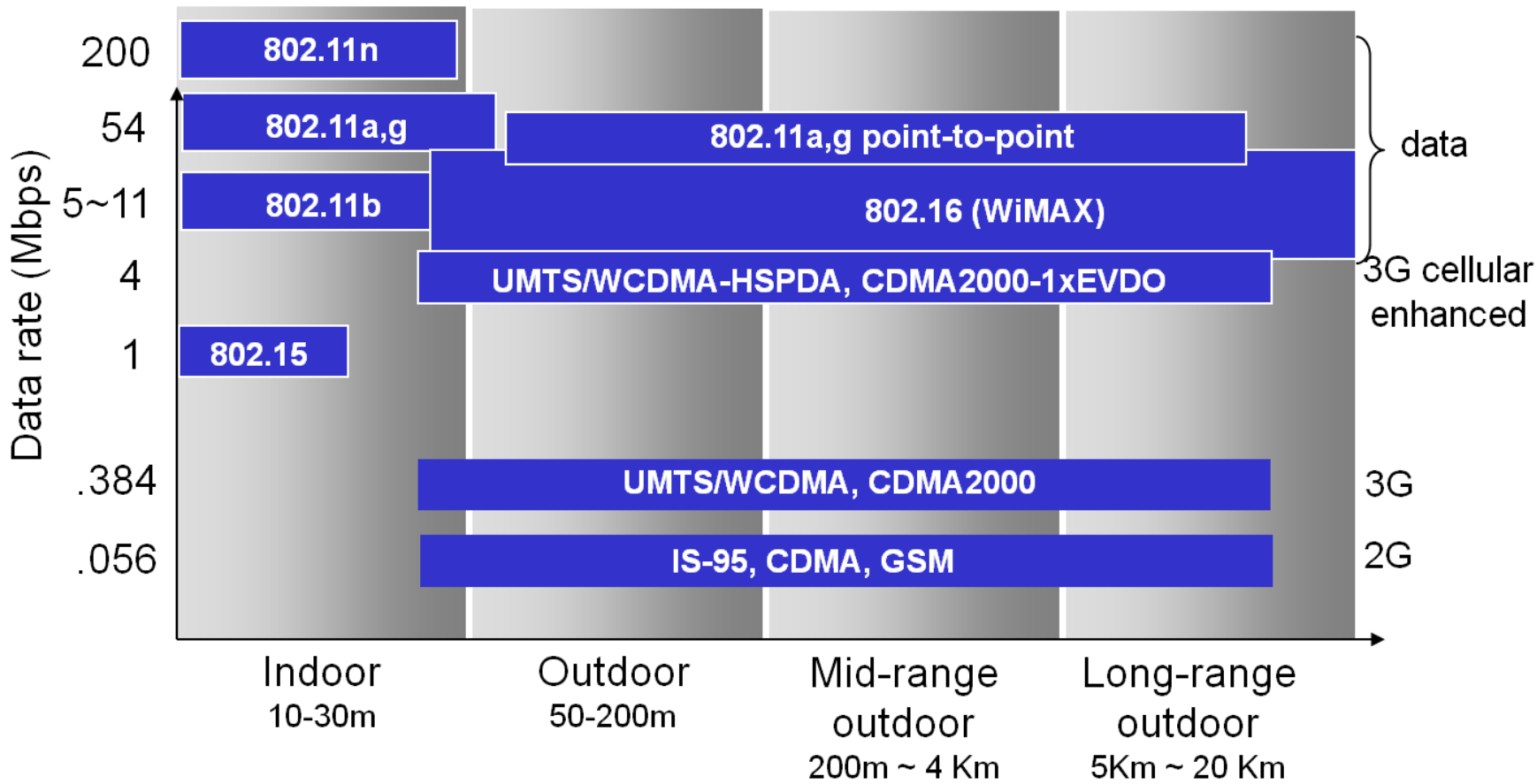



Two modes of operation

- **Infrastructure mode**: Base stations connect mobiles to wired network
- **Ad-hoc mode**: Wireless hosts organize themselves to communicate



Infrastructure mode

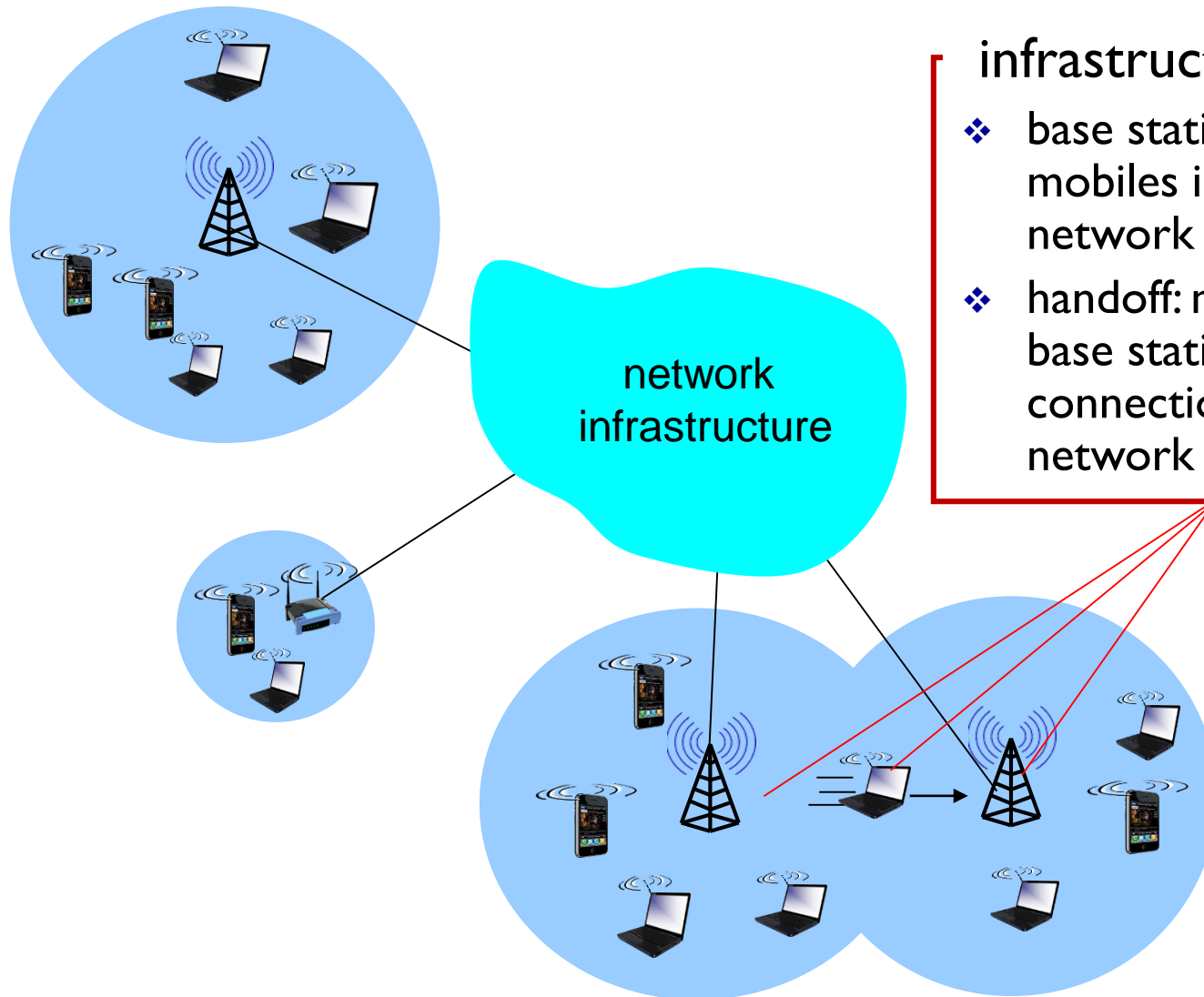

infrastructure mode

- ❖ base station connects mobiles into wired network
- ❖ handoff: mobile changes base station providing connection into wired network



Ad-hoc mode

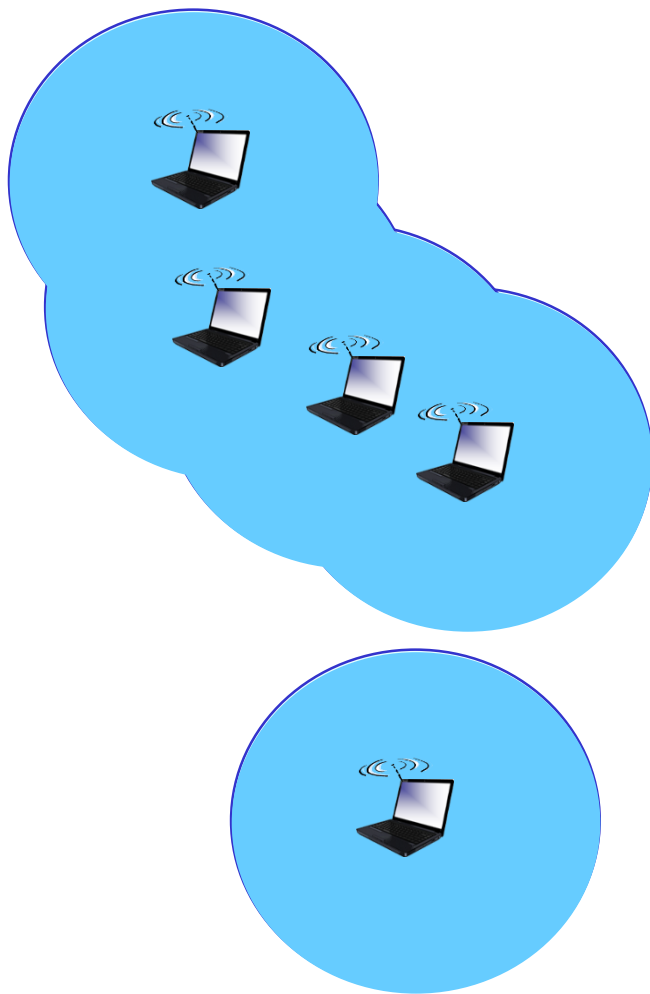

ad hoc mode

- ❖ no base stations
- ❖ nodes can only transmit to other nodes within link coverage
- ❖ nodes organize themselves into a network: route among themselves



Ad-hoc Networking

- **Peer-to-peer communication**, no base stations
- Nodes organize themselves into a network: route among themselves

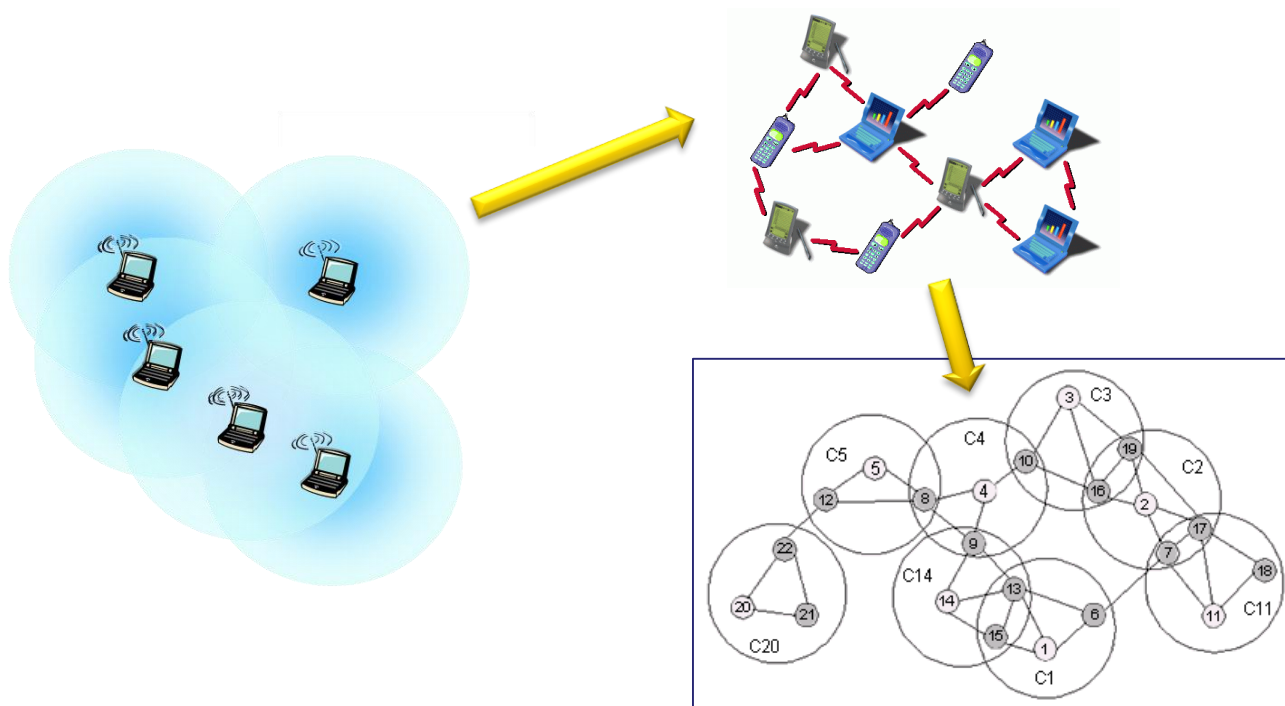



Wireless network taxonomy

	single hop	multiple hops
infrastructure (e.g., APs)	host connects to base station (WiFi, WiMAX, cellular) which connects to larger Internet	host may have to relay through several wireless nodes to connect to larger Internet: <i>mesh net</i>
no infrastructure	no base station, no connection to larger Internet (Bluetooth, ad hoc nets)	no base station, no connection to larger Internet. May have to relay to reach other a given wireless node MANET, VANET



Wireless link characteristics

- Three important differences from wired link
 - ...
 - (1) **Decreased signal strength**: Radio signal attenuates as it propagates through matter (path loss)



Path loss/path attenuation

- Free Space Path Loss (FSPL):

$$\text{FSPL} = \left(\frac{4\pi df}{c} \right)^2$$

- d = distance
- λ = wave length (c/f)
- f = frequency
- c = speed of light

- Due to

- Reflection, diffraction, absorption, terrain contours (urban, rural, vegetation), humidity



SNR and BER

- **SNR**: Signal-to-noise ratio
 - Larger SNR makes it easier to extract signal from noise (good)
- **BER**: Bit error rate
- SNR vs. BER tradeoffs
 - **Given physical layer**: Increase power \rightarrow increase SNR \rightarrow decrease BER
 - **Given SNR**: Choose physical layer that meets BER requirement, giving highest throughput
 - **SNR may change with mobility**: Dynamically adapt physical layer

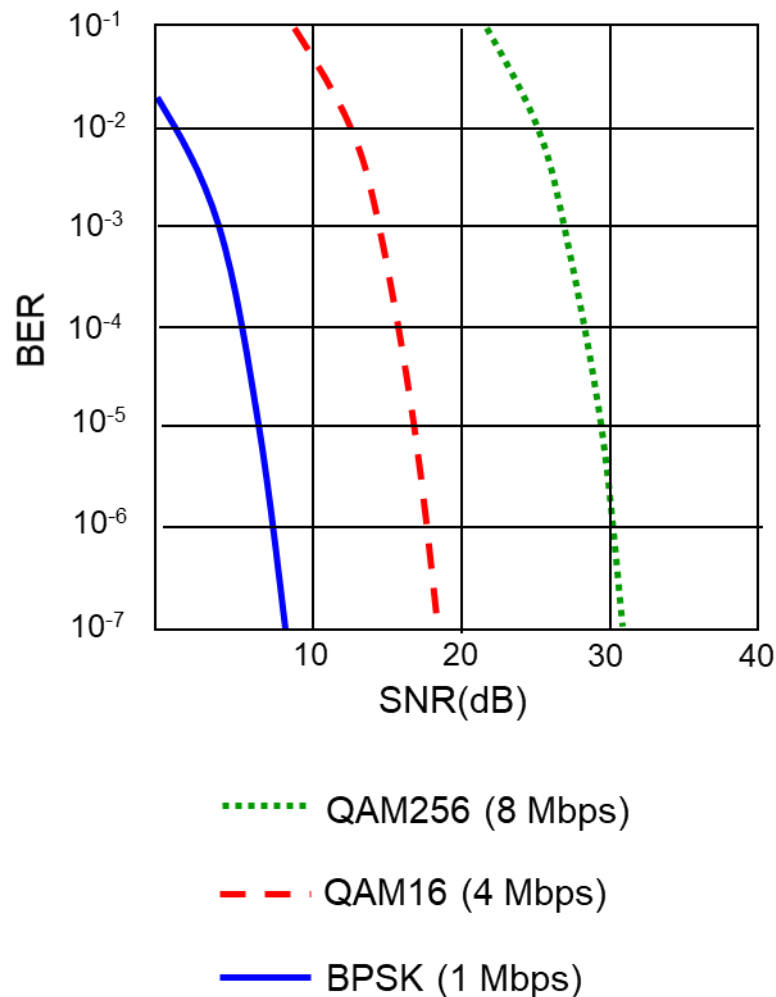



Wireless link characteristics

- Three important differences from wired link
 - ...
 - (1) Decreased signal strength: Radio signal attenuates as it propagates through matter (path loss)
 - (2) **Multipath propagation**: Radio signal reflects off objects ground, arriving ad destination at slightly different times



Multipath effects

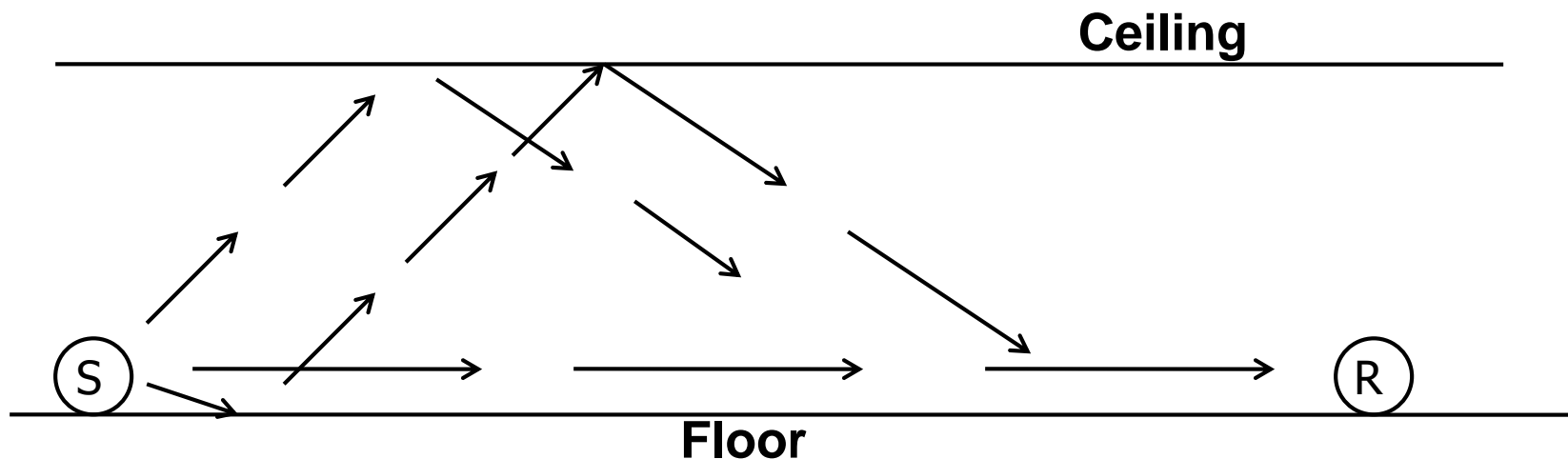

- Signals bounce off surface and interfere with one another
- Self-interference



Wireless link characteristics

- Three important differences from wired link ...
 - (1) Decreased signal strength: Radio signal attenuates as it propagates through matter (path loss)
 - (2) Multipath propagation: Radio signal reflects off objects ground, arriving at destination at slightly different times
 - (3) **Interference from other sources**: Standardized wireless network frequencies (e.g., 2.4 GHz) shared by other devices (e.g., phone); devices (motors) interfere as well
- ... make communication across (even a point-to-point) wireless link much more “difficult”



Wireless network characteristics

- Broadcast medium
 - Anybody in proximity can hear and interfere
- Cannot receive while transmitting
 - Our own (or nearby) transmission is deafening our receiver ⇒ **Half-duplex**
 - Recent work has shown that full duplex may also be possible
- Signals sent by sender don't always end up at receiver intact
- Multiple wireless senders and receivers create many problems
 - Multiple access issues (we've seen this before)
 - **Hidden terminal problem**



WiFi - IEEE 802.11 Wireless LANs



IEEE 802.11 Wireless LANs

- A single-cell configuration

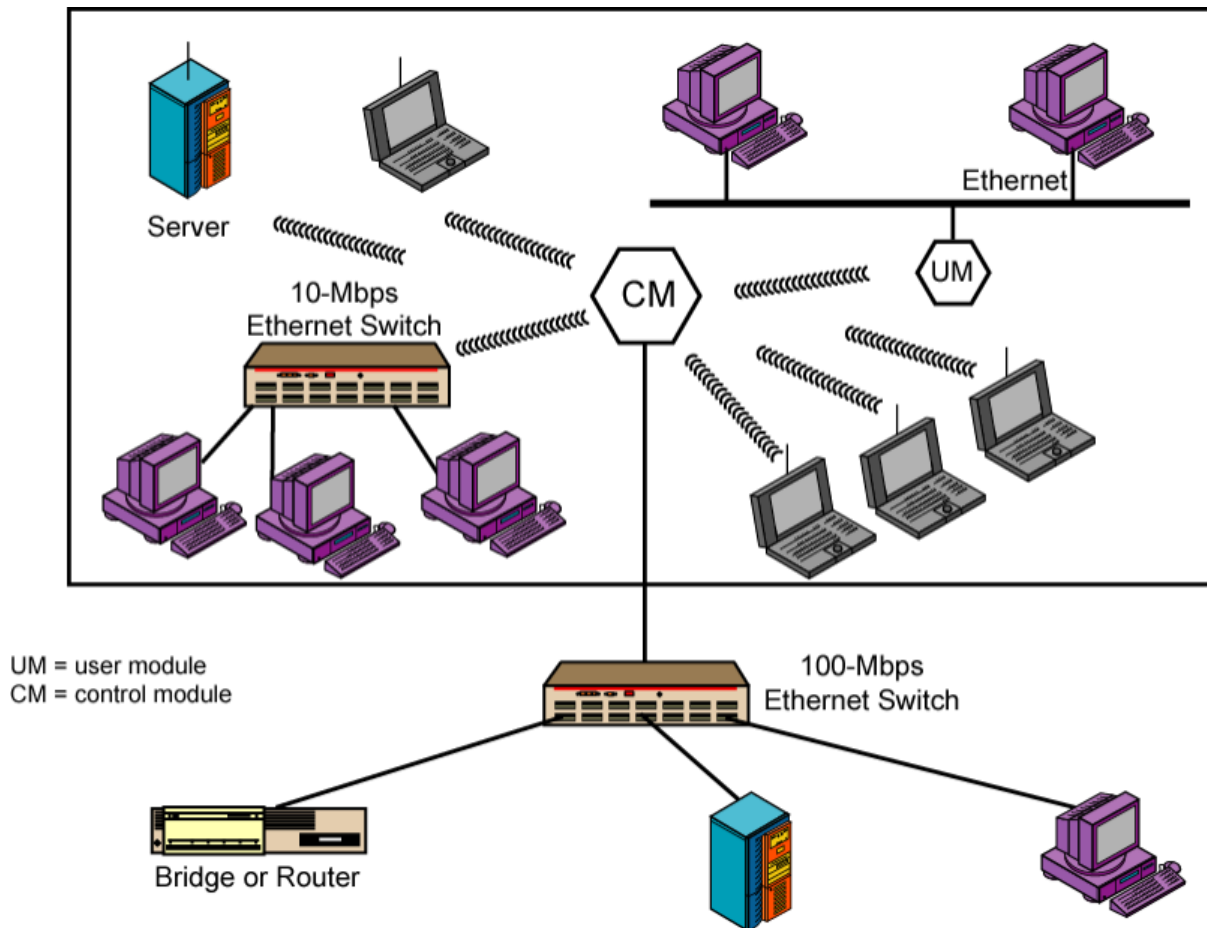



A Multi-Cell Configuration

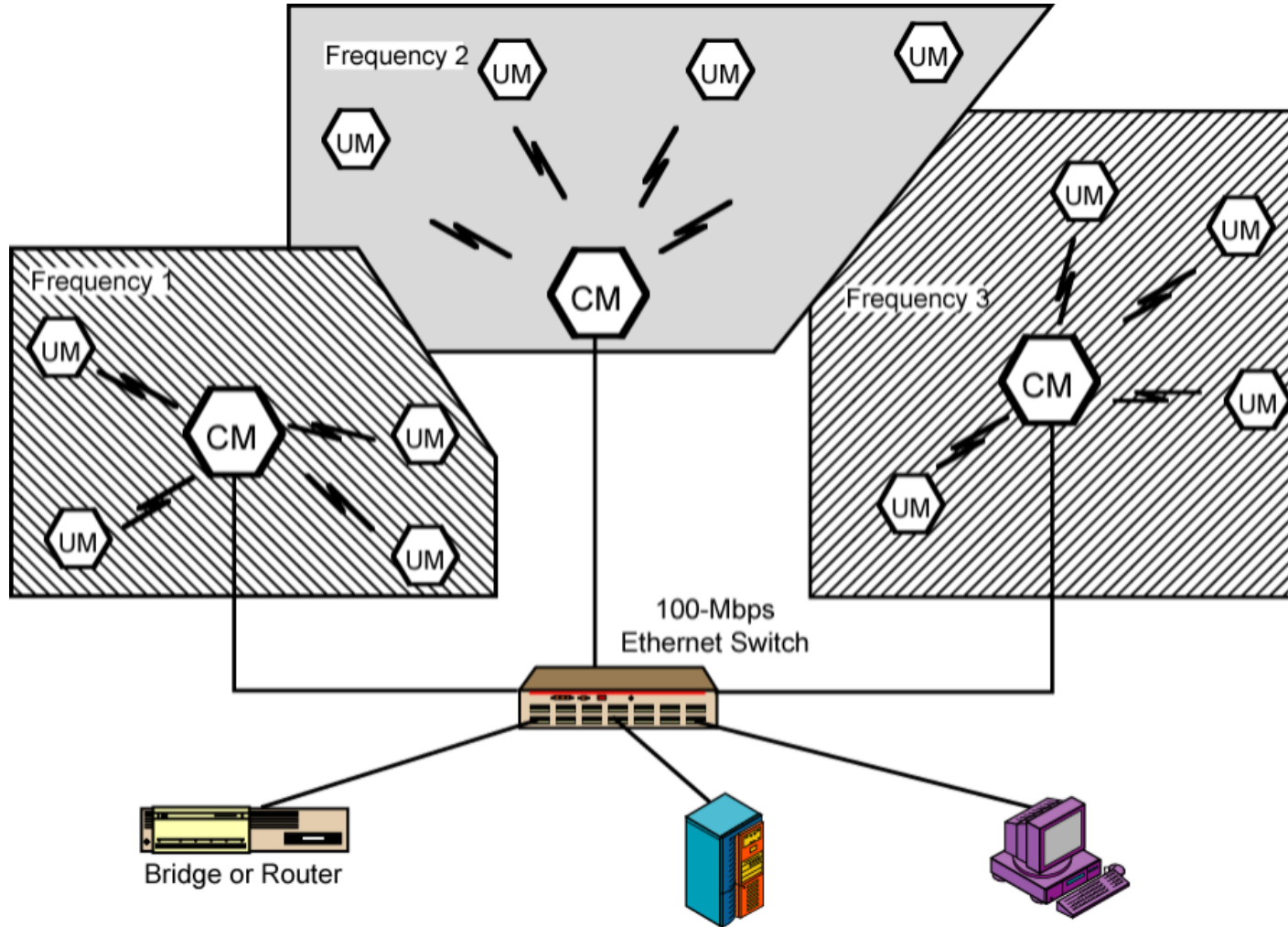



IEEE 802.11 Architecture

- **Station:** device with IEEE 802.11 conformant MAC and physical layer
- **Access Point (AP):**
 - Provides access to the distribution system via the wireless medium
- **Basic Service Set (BSS)**
 - A single cell coordinated by one access point (base station)
- **Extended Service Set (ESS)**
 - Multiple BSSs interconnected by **Distribution System** (DS)
 - DS can be a switch, wired network, or wireless network
 - An ESS appears as a **single logical LAN**
 - Portals (routers) provide access to Internet
- **Distribution System (DS):**
 - A system used to interconnect a set of BSSs and integrated LANs to create an (ESS)

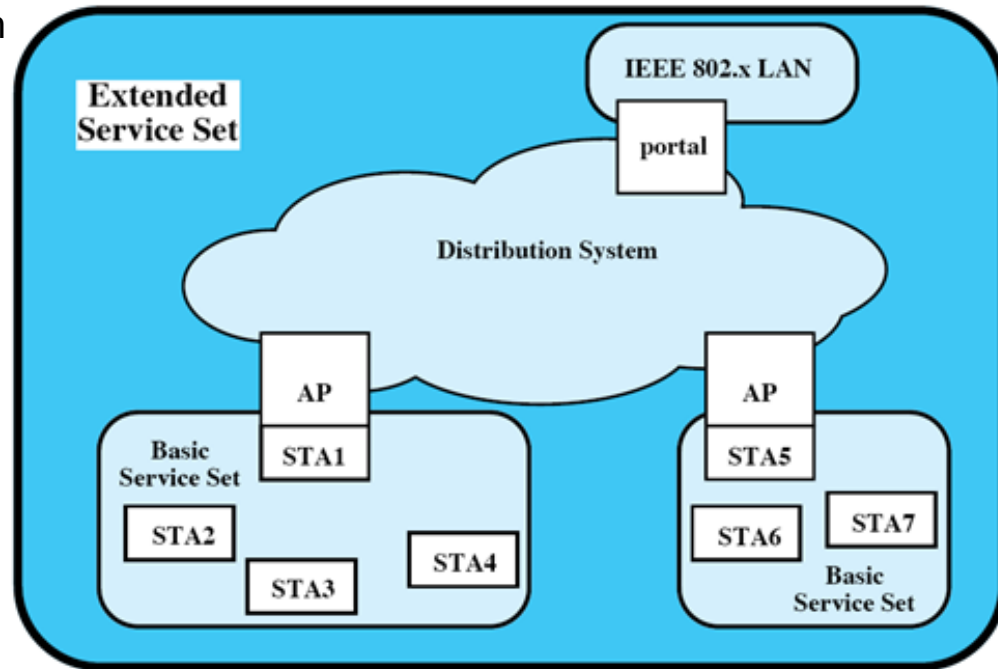

STA = station
AP = access point



Possible Communications

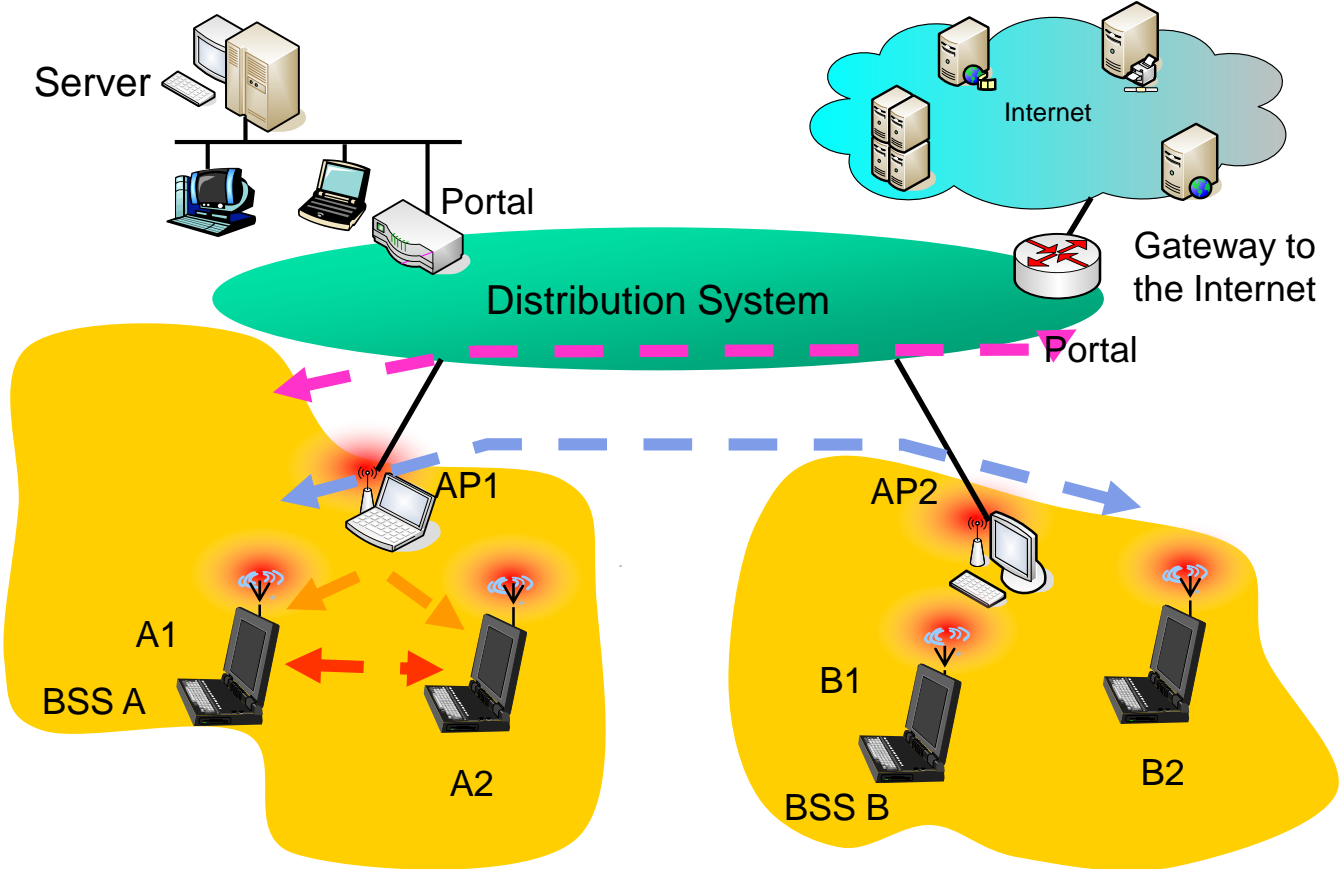



802.11: Channels, association

- 802.11b: 2.4GHz-2.485GHz spectrum divided into 11 channels at different frequencies
 - AP admin chooses frequency for AP
 - interference possible: channel can be same as that chosen by neighboring AP!
- Host: must *associate* with an AP
 - scans channels, listening for *beacon frames* containing AP' s name (SSID) and MAC address
 - selects AP to associate with
 - may perform authentication
 - will typically run DHCP to get IP address in AP' s subnet



Scanning for Association

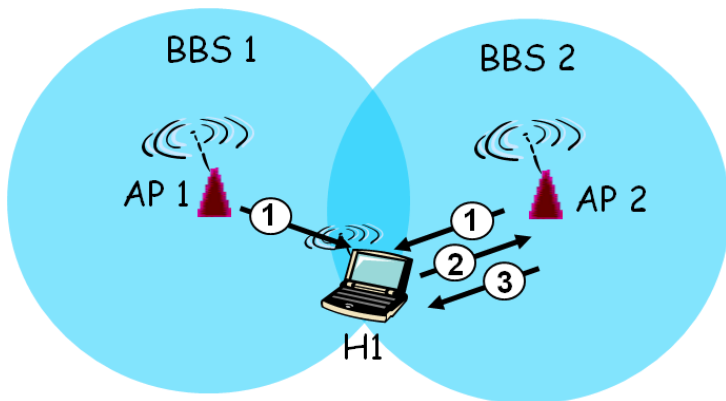

Passive Scanning:

- Beacon frames sent from Aps
- Association Request frame sent: H1 to selected AP
- Association Response frame sent: selected AP to H1

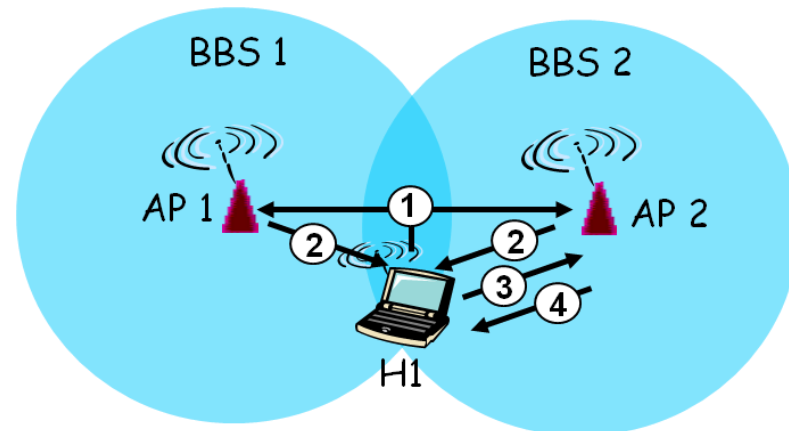

Active Scanning:

- Probe Request frame broadcast from H1
- Probe response frame sent from APs
- Association Request frame sent: H1 to selected AP
- Association Response frame sent: selected AP to H1



IEEE 802.11: Multiple Access

- Multiple wireless senders and receivers create additional problems (beyond multiple access)

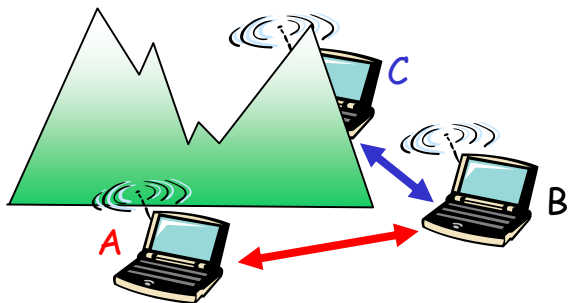

Hidden terminal problem

- B, A hear each other
- B, C hear each other
- A, C can not hear each other
- A, C unaware of their interference at B

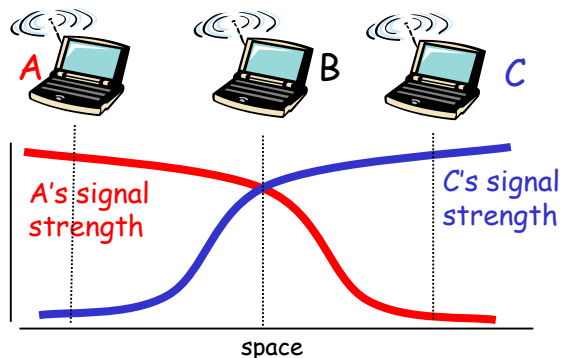

Signal fading problem

- B, A hear each other
- B, C hear each other
- A, C can not hear each other interfering at B

Exposed terminal problem

- S1, S2 hear each other
- S2 waits when it hears S1 transmitting
- But S1->R1 and S2->R2 can transfer simultaneously since they are not interference

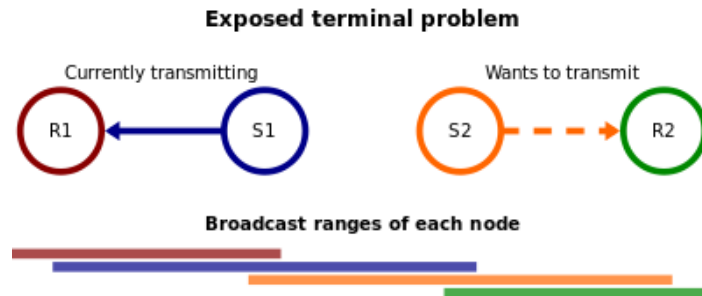



4 Frame Exchange

- Solving the hidden terminal problem: using **RTS/CTS**
- To enhance wireless reliability, **4-frame exchange** may be used
 - Source issues a **Request to Send** (RTS) frame to destination
 - Destination responds with **Clear to Send** (CTS)
 - After receiving CTS, source transmits data
 - Destination responds with **ACK**
- Stations refrain from transmission to avoid collision
 - RTS alerts all stations within **range of source** that exchange is under way
 - CTS alerts all stations within **range of destination**
- RTS/CTS exchange is a required function, but can be disabled

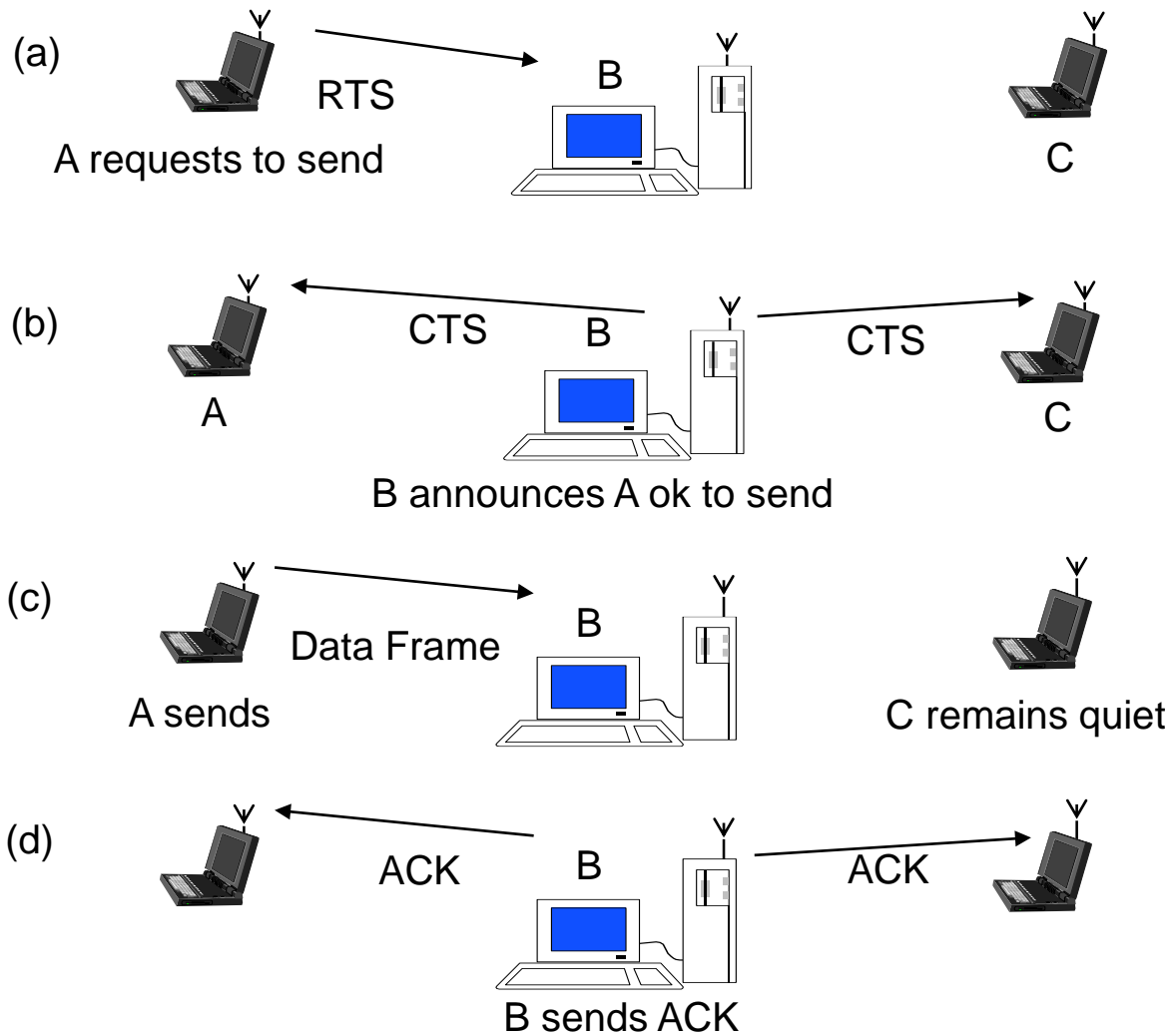



IEEE 802.11 Protocol Architecture

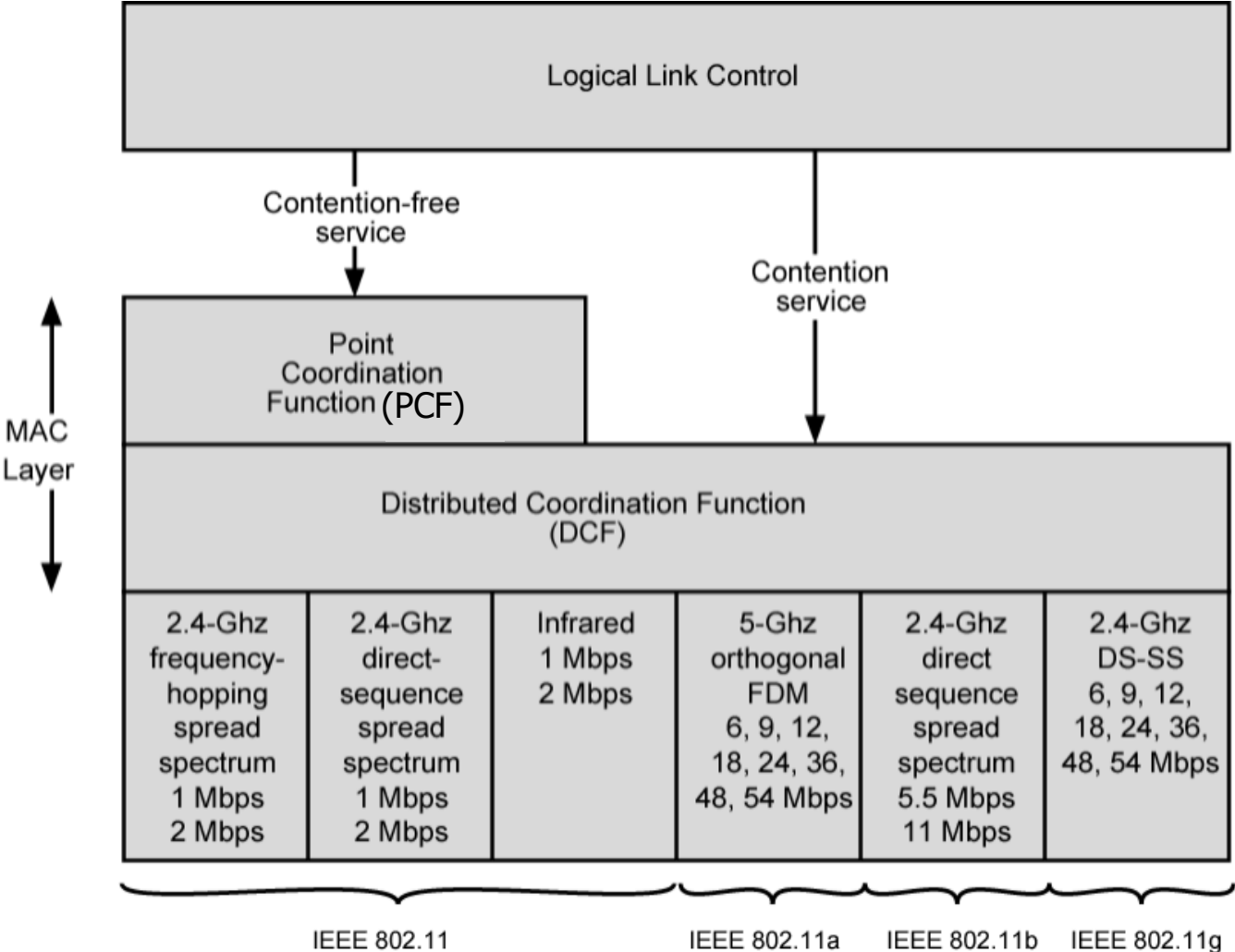



Media Access Control

- Distributed wireless foundation MAC (DWFMAC, 分布式基础无线媒体访问控制)
 - Distributed access control mechanism
 - Optional centralized control on top
- The lower sub-layer is distributed coordination function (**DCF**, 分布式协调功能, 分布式控制, 用于传输异步数据, 优先级最低)
 - Contention algorithm to provide access to all traffic
 - CSMA/CA (collision avoidance)
- The upper is point coordination function (**PCF**, 点协调功能, 集中式控制, 用于发送实时数据, 优先级仅次于控制帧)
 - Centralized MAC algorithm, Contention free
 - Built on top of DCF



3-level Priority

- SIFS (Short Inter Frame Space)
 - Shortest IFS – **highest priority**
 - For all immediate responses
- PIFS (point coordination function IFS)
 - Mid-length IFS
 - Used by the centralized controller in PCF scheme when issuing polls
- DIFS (distributed coordination function IFS)
 - Longest IFS
 - Used for other asynchronous frames contending for access

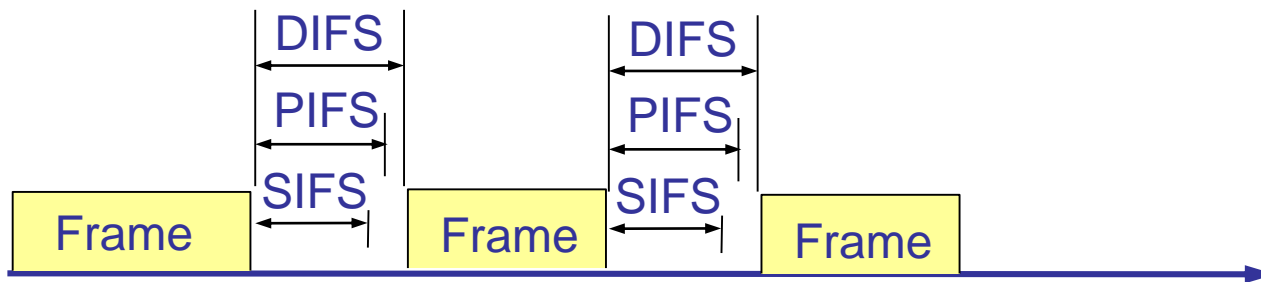



SIFS Use

- **Acknowledgment (ACK)**
 - Station responds with ACK after waiting SIFS gap
- **Delivery of multiple frame LLC PDU**
 - Station with multi-frame LLC PDU to transmit sends out 1st MAC frame using normal IFS
 - Each subsequent frames sent after SIFS
- **Poll response**
 - Response frame after poll
- **Clear to Send (CTS)**
 - Station can ensure data frame will get through by issuing RTS with normal IFS
 - Destination station should respond with CTS using SIFS if ready to receive



PIFS and DIFS

- PIFS used by centralized controller
 - Issuing polls
 - Takes precedence over normal contention traffic
 - Frames using SIFS have precedence over PCF poll
- DIFS used for all ordinary asynchronous traffic



IEEE 802.11 Medium Access Control Logic

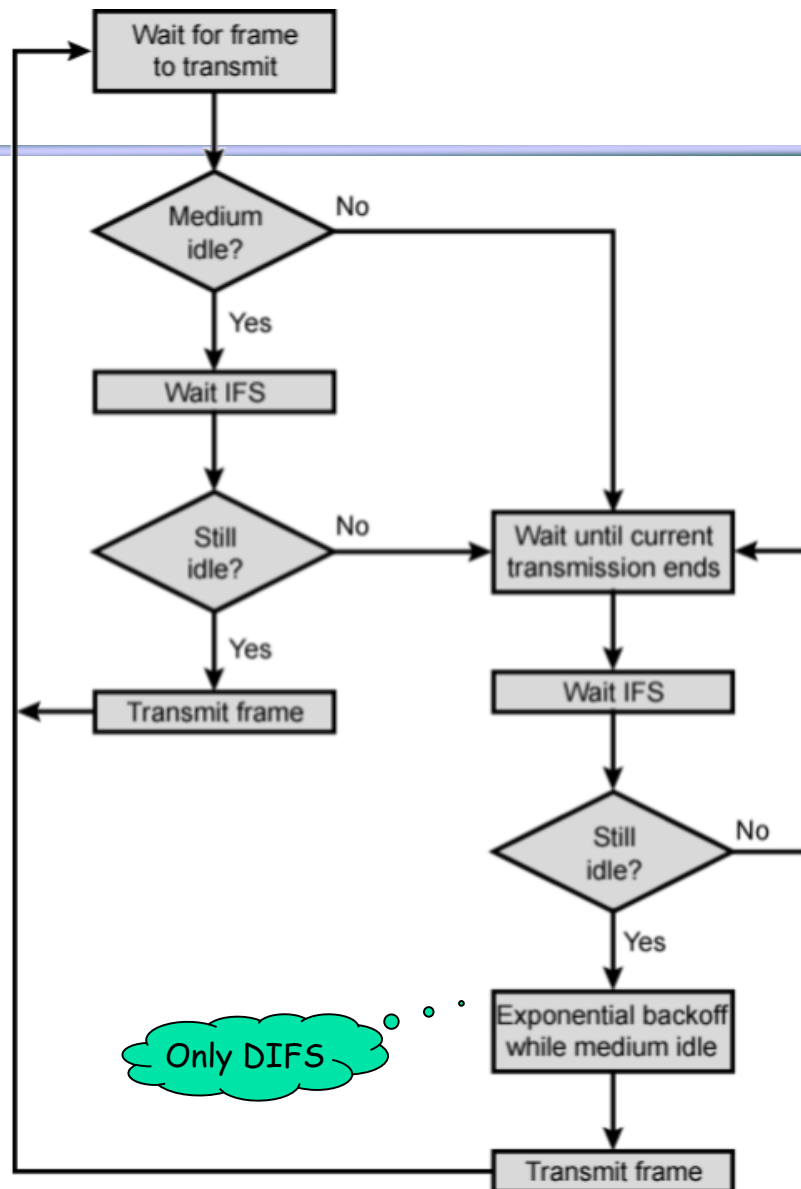



Point Coordination Function (PCF)

- Polling by **centralized polling master** (point coordinator)
 - Uses PIFS (<DIFS) when issuing polls
 - Can seize medium and lock out all asynchronous traffic while it issues polls and receives responses
- Wireless network configured a number of stations with **time-sensitive traffic** are controlled by point coordinator
 - Point coordinator polls in **round-robin** to stations configured for polling
 - When poll issued, polled station may respond using SIFS
 - If point coordinator receives response, it issues another poll using PIFS
 - If no response during expected turnaround time, coordinator issues another poll
 - Repeat until current round ended



Super-frame

- Super-frame **defined by PCF**
 - During first part of super-frame interval, point coordinator polls round-robin to all polling stations
 - Remainder of super-frame allows contention period for asynchronous access
- At beginning of super-frame, point coordinator creates **a contention-free period**
 - Time varies because of variable frame size issued by responding stations
 - Rest of super-frame available for contention-based access
- At end of super-frame interval, point coordinator contends for access using **PIFS**
 - By beacon frame, results in super-frame period for next cycle

超级帧：

点协调器不断发布轮询，会封锁所有异步通信量。为了避免这种情况，在超帧时间的前一部分，由点协调器轮询，在超帧时间的后一部分，允许异步通信量争用接入。



IEEE 802.11 MAC Timing – PCF

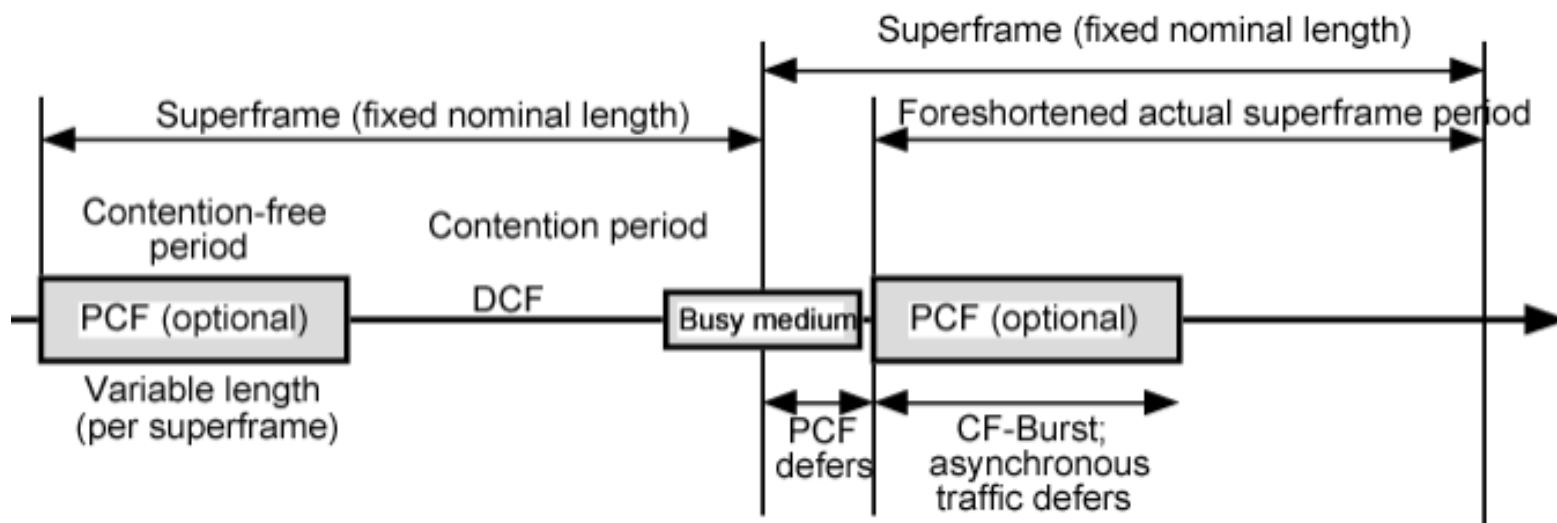



Distributed Coordination Function

- The DCF sub-layer uses **CSMA/CA (collision avoidance)**
 - Station senses medium before transmitting
 - Don't collide with ongoing transmission by other station
- DCF includes **delays**
 - Inter-frame space (IFS), station wait for IFS before transmitting
 - Accounts for **priority scheme**
- **No collision detection, why?**
 - Difficult to receive (sense collisions) when transmitting due to weak received signals (fading)
 - Transmitting station cannot distinguish incoming weak signals from noise and effects of own transmission
 - Can't sense all collisions in any case: hidden terminal, fading
 - **ACK** is used for success transmission



IEEE 802.11 MAC Protocol: CSMA/CA

802.11 sender

- 1 if sense channel idle for **DIFS** then transmit entire frame (no CD)
- 2 if sense channel busy then start random backoff time
timer counts down while channel idle
transmit when timer expires
if no ACK, increase random backoff interval, repeat 2

802.11 receiver

- if frame received OK
return ACK after **SIFS** (ACK needed due to hidden terminal problem)

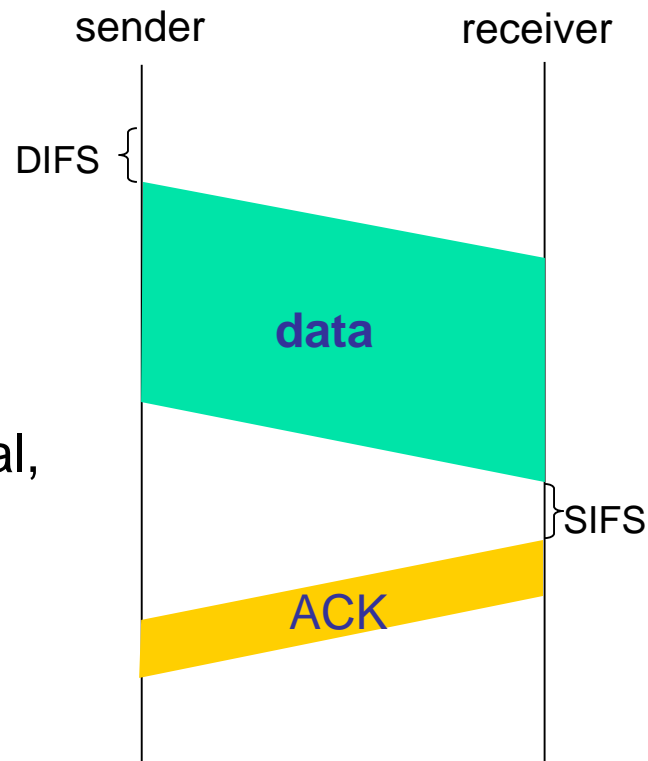



IEEE 802.11 MAC Timing – DCF

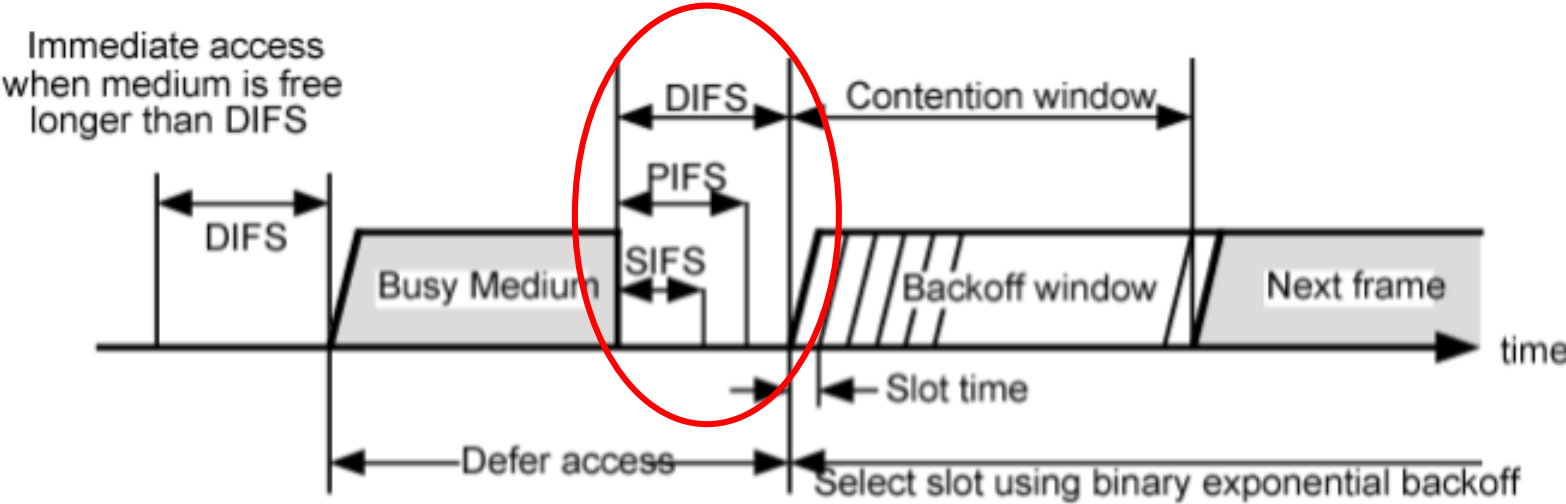

(a) Basic Access Method



IEEE 802.11 Medium Access Control Logic

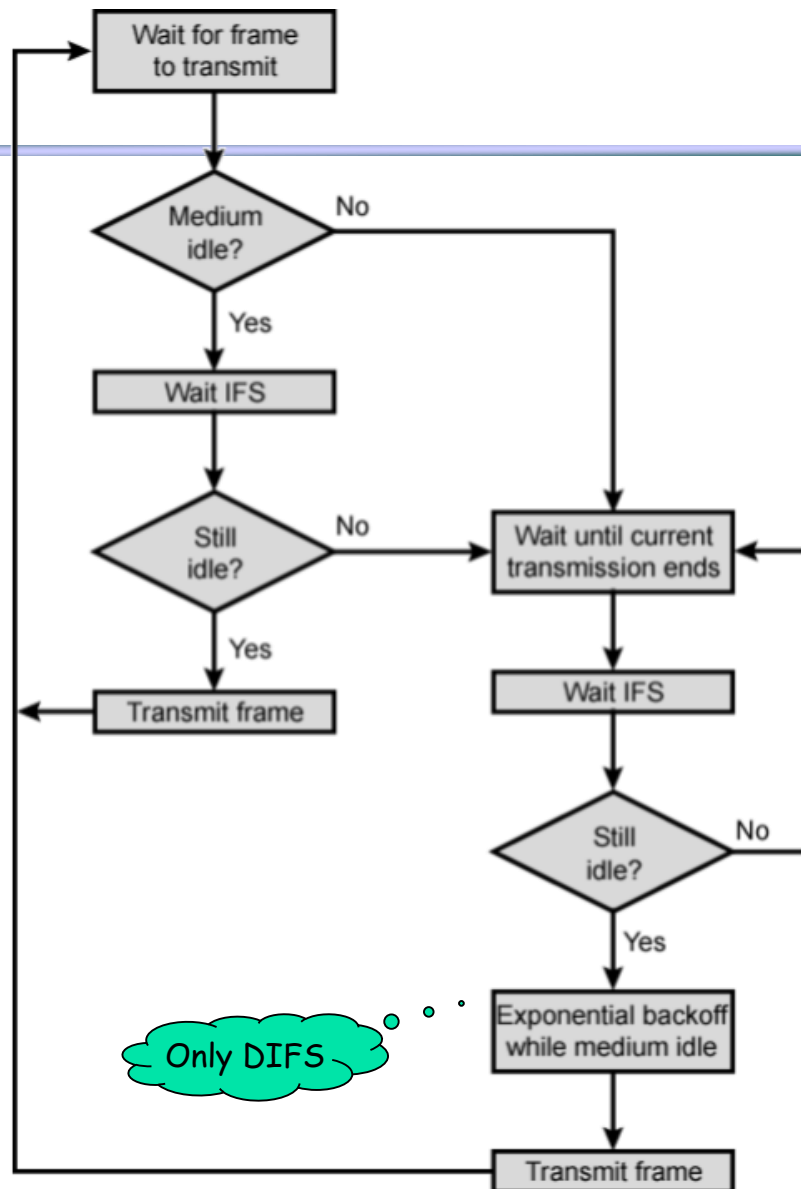



802.11 frame: addressing

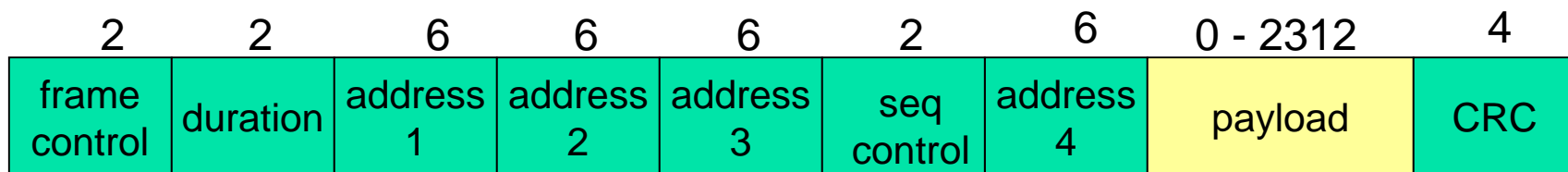

Address 1: MAC address of wireless host or AP to receive this frame

Address 2: MAC address of wireless host or AP transmitting this frame

Address 3: MAC address of router interface to which AP is attached

Address 4: used only in ad hoc mode



Why do we need Address 3?

Integrate 802.11 and 802.3 nets

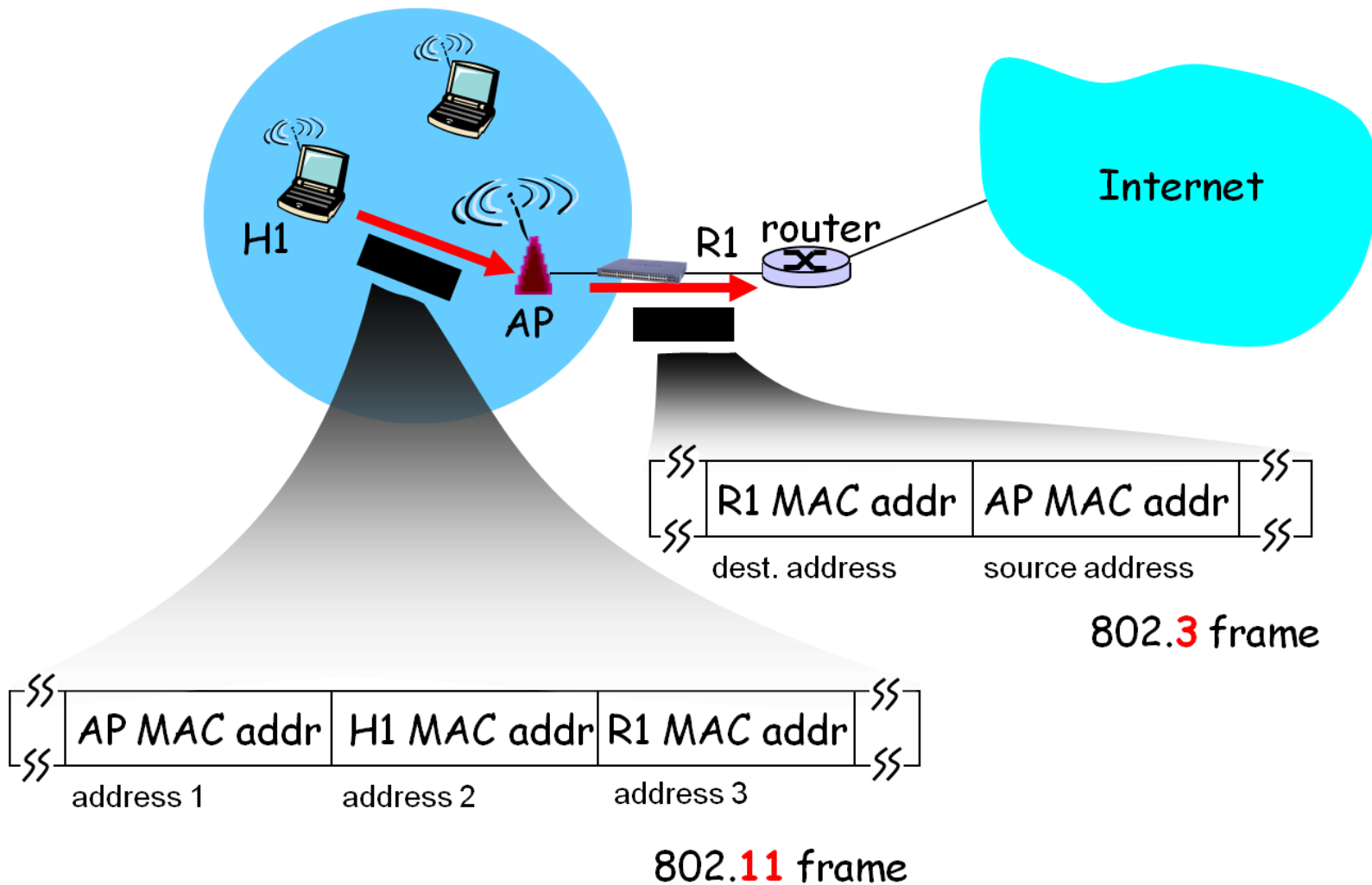



802.11: mobility within same subnet

- HI remains in same IP subnet: IP address can remain same
- switch: which AP is associated with HI?
 - self-learning: switch will see frame from HI and “remember” which switch port can be used to reach HI

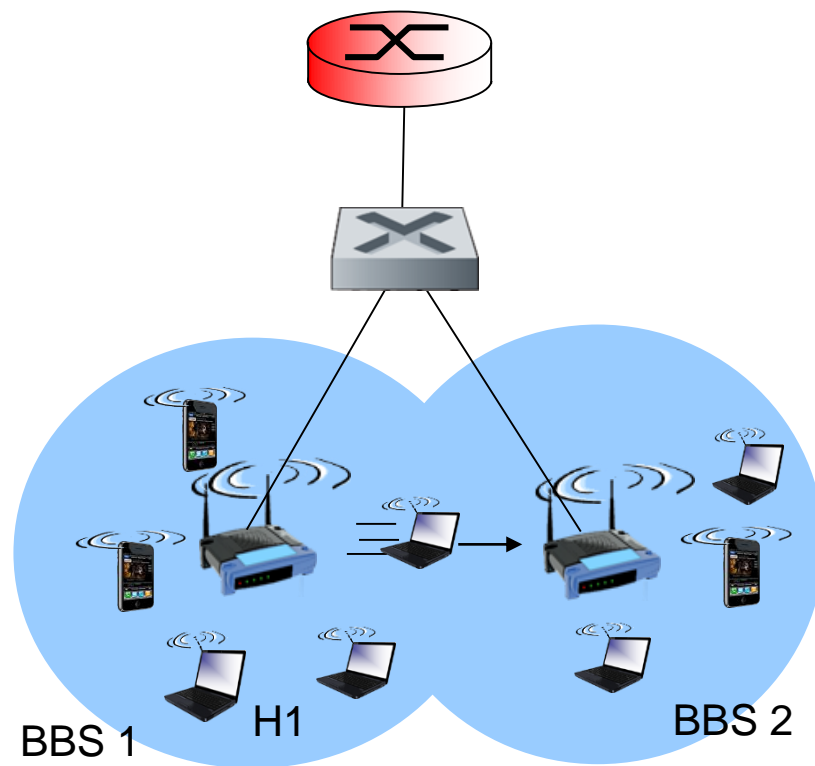



802.11: advanced capabilities

Rate adaptation

- ❖ base station, mobile dynamically change transmission rate (physical layer modulation technique) as mobile moves, SNR varies

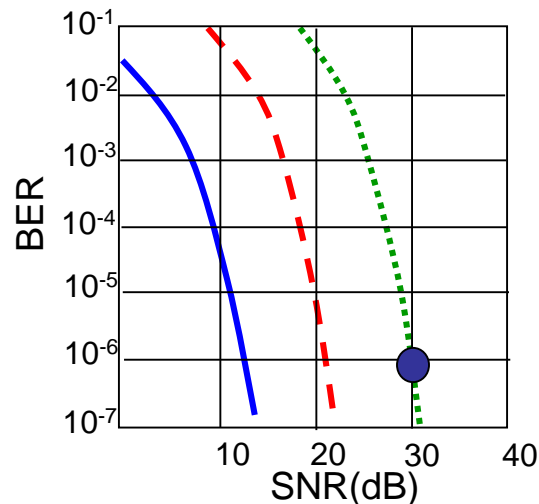
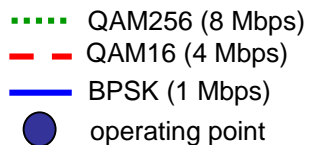

1. SNR decreases, BER increase as node moves away from base station
2. When BER becomes too high, switch to lower transmission rate but with lower BER



802.11: advanced capabilities

power management

- ❖ node-to-AP: “I am going to sleep until next beacon frame”
 - AP knows not to transmit frames to this node
 - node wakes up before next beacon frame
- ❖ beacon frame: contains list of mobiles with AP-to-mobile frames waiting to be sent
 - node will stay awake if AP-to-mobile frames to be sent; otherwise sleep again until next beacon frame



南京大學

NANJING UNIVERSITY



Cellular Network



Components of cellular network architecture

cell

- ❖ covers geographical region
- ❖ *base station* (BS) analogous to 802.11 AP
- ❖ *mobile users* attach to network through BS
- ❖ *air-interface*: physical and link layer protocol between mobile and BS

MSC

- ❖ connects cells to wired tel. net.
- ❖ manages call setup (more later!)
- ❖ handles mobility (more later!)

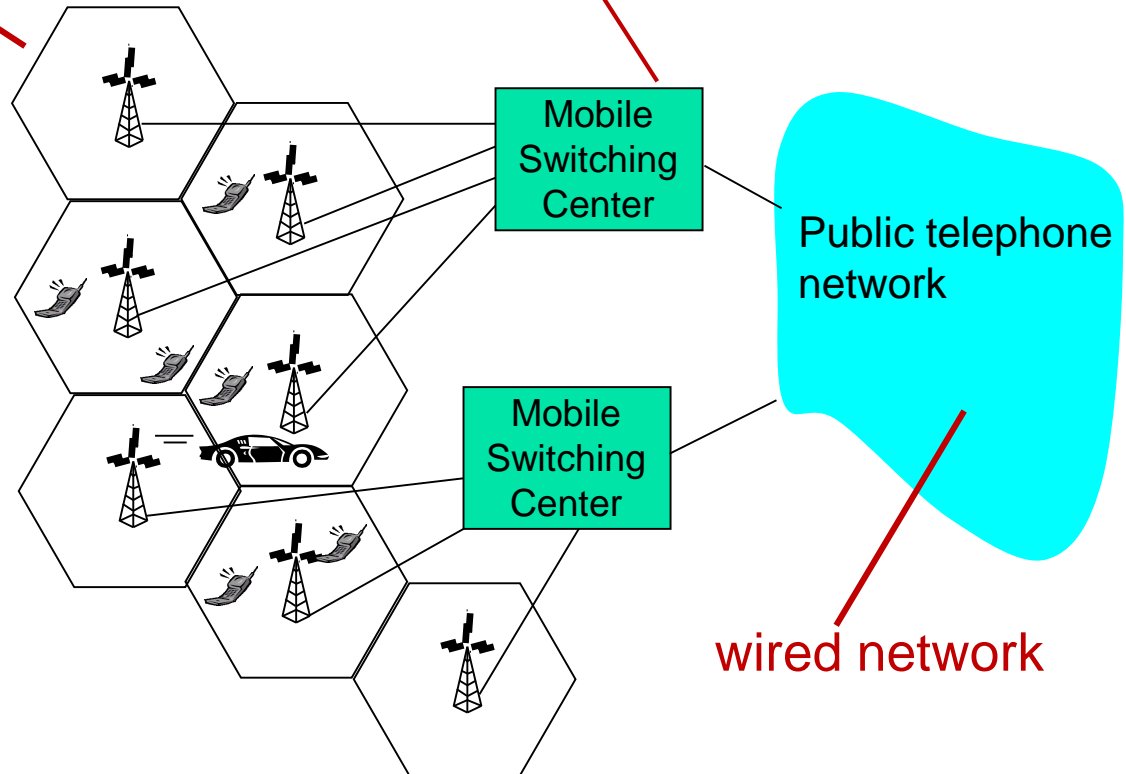



Cellular networks: the first hop

Two techniques for sharing mobile-to-BS radio spectrum

- ❖ **combined FDMA/TDMA:** divide spectrum in frequency channels, divide each channel into time slots
- ❖ **CDMA:** code division multiple access

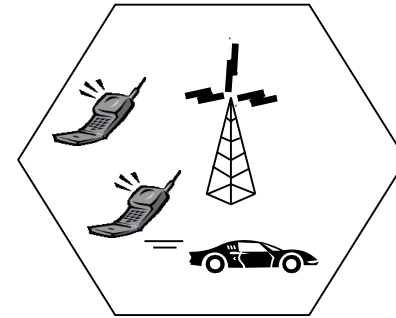

time slots

frequency bands

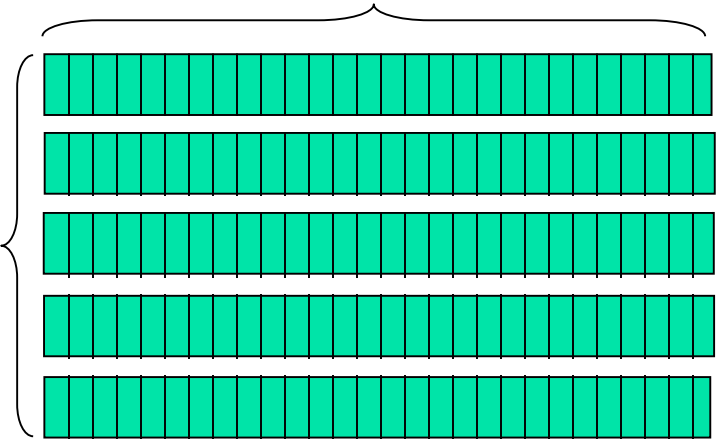



2G (voice) network architecture

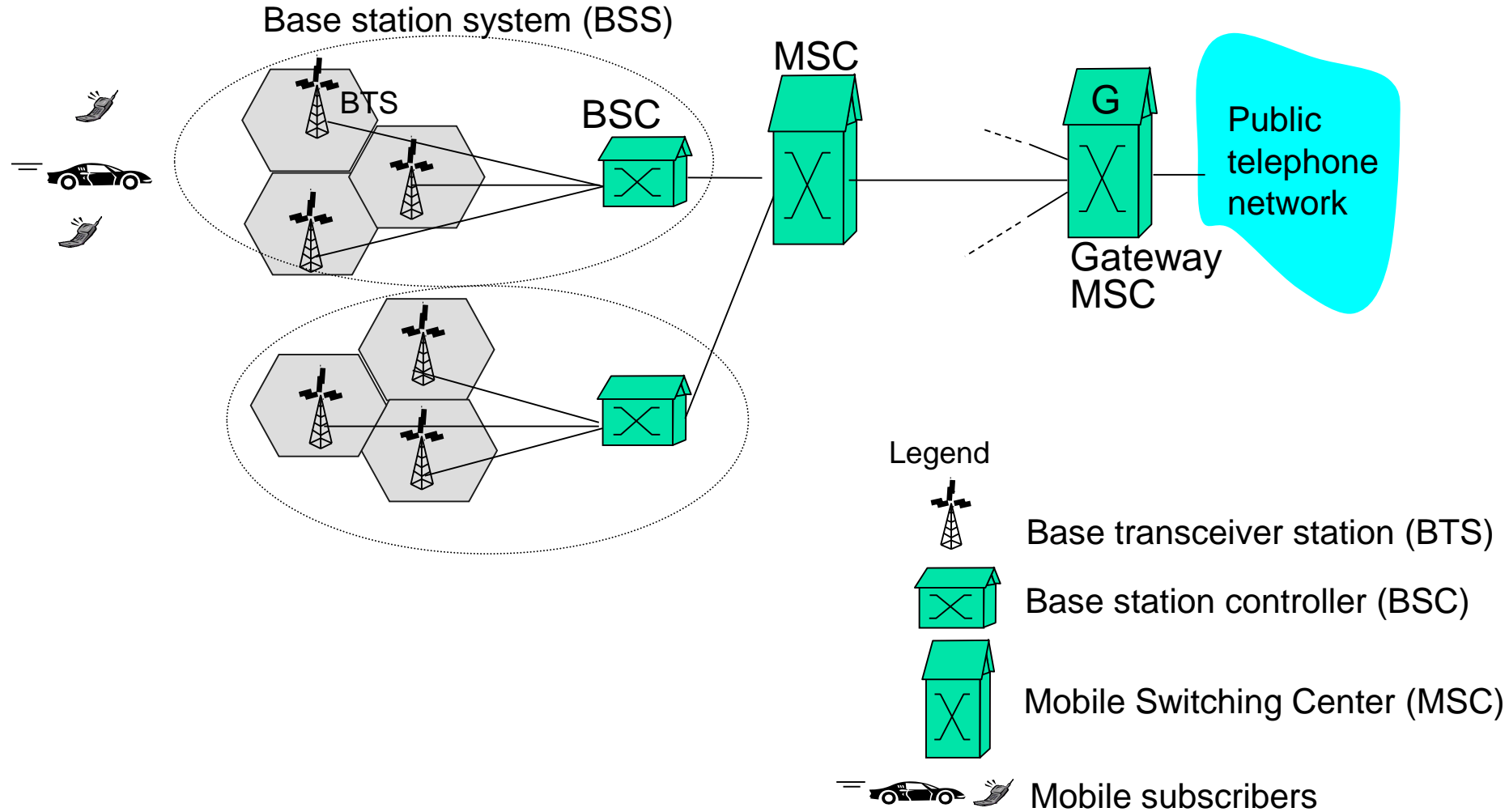



3G (voice+data) network architecture

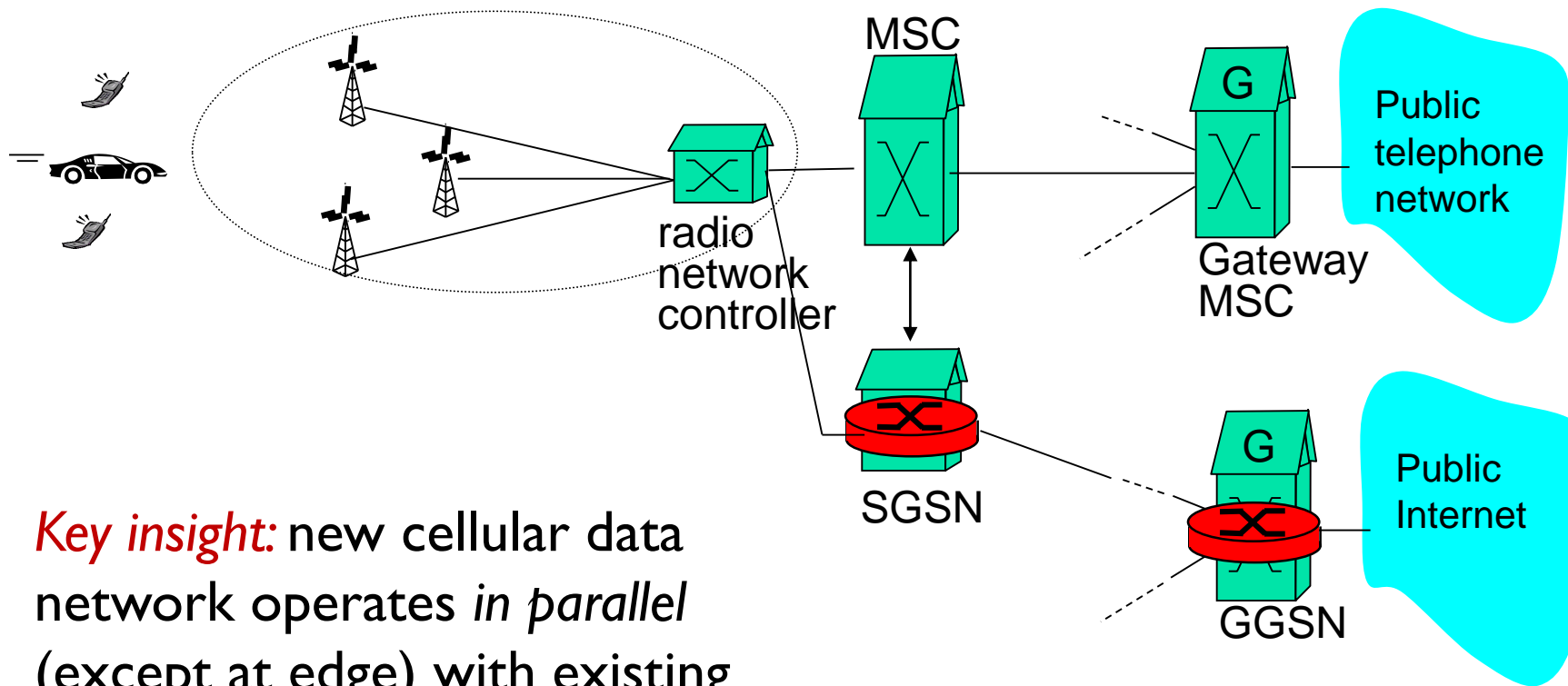

Key insight: new cellular data network operates *in parallel* (except at edge) with existing cellular voice network

- ❖ voice network unchanged in core
- ❖ data network operates in parallel

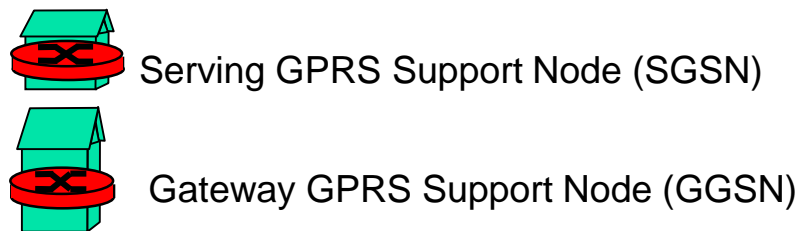



3G (voice+data) network architecture

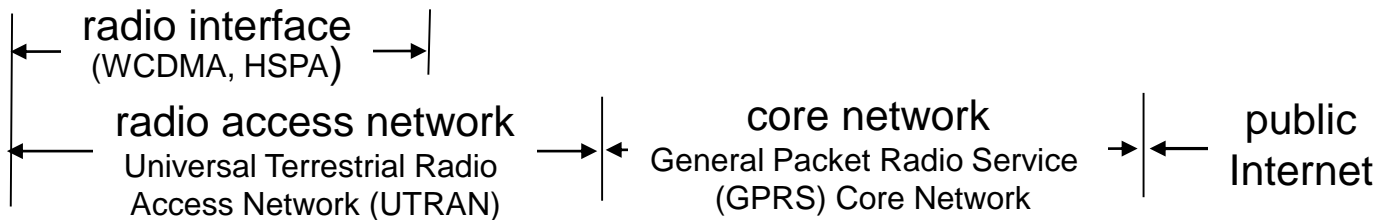
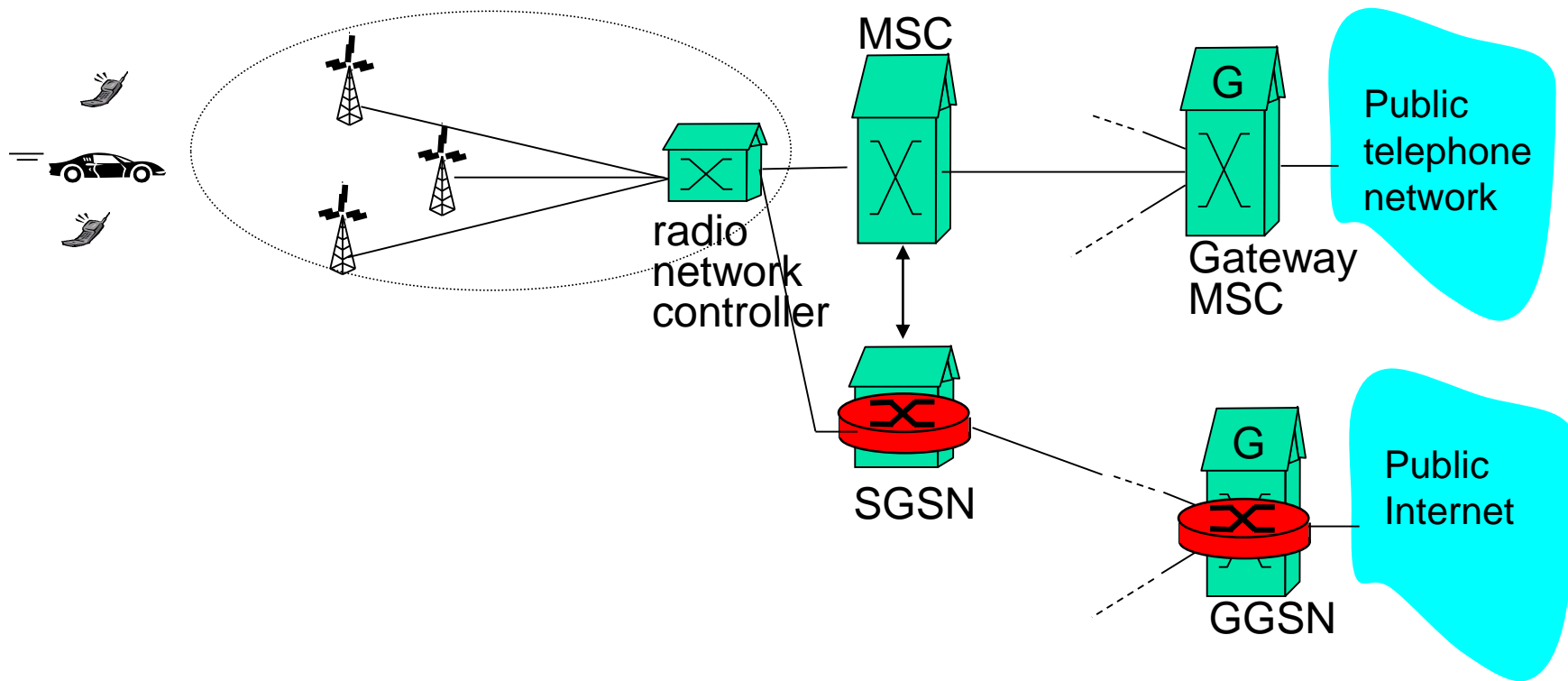



4G

- Developed in 2010
- OFDM, MIMO, ...
- Faster & more reliable
- Speed up to 100 Mbps
- High performance
- Easy roaming
- Low cost





5G

- Next major phase of mobile telecommunication & wireless system
- Massive MIMO, mmWave, ...
- 10 times more capacity than others
- Expected speed up to 1 Gbps
- More faster & reliable than 4G
- Lower cost than previous generations





Evolution of mobile phone communications

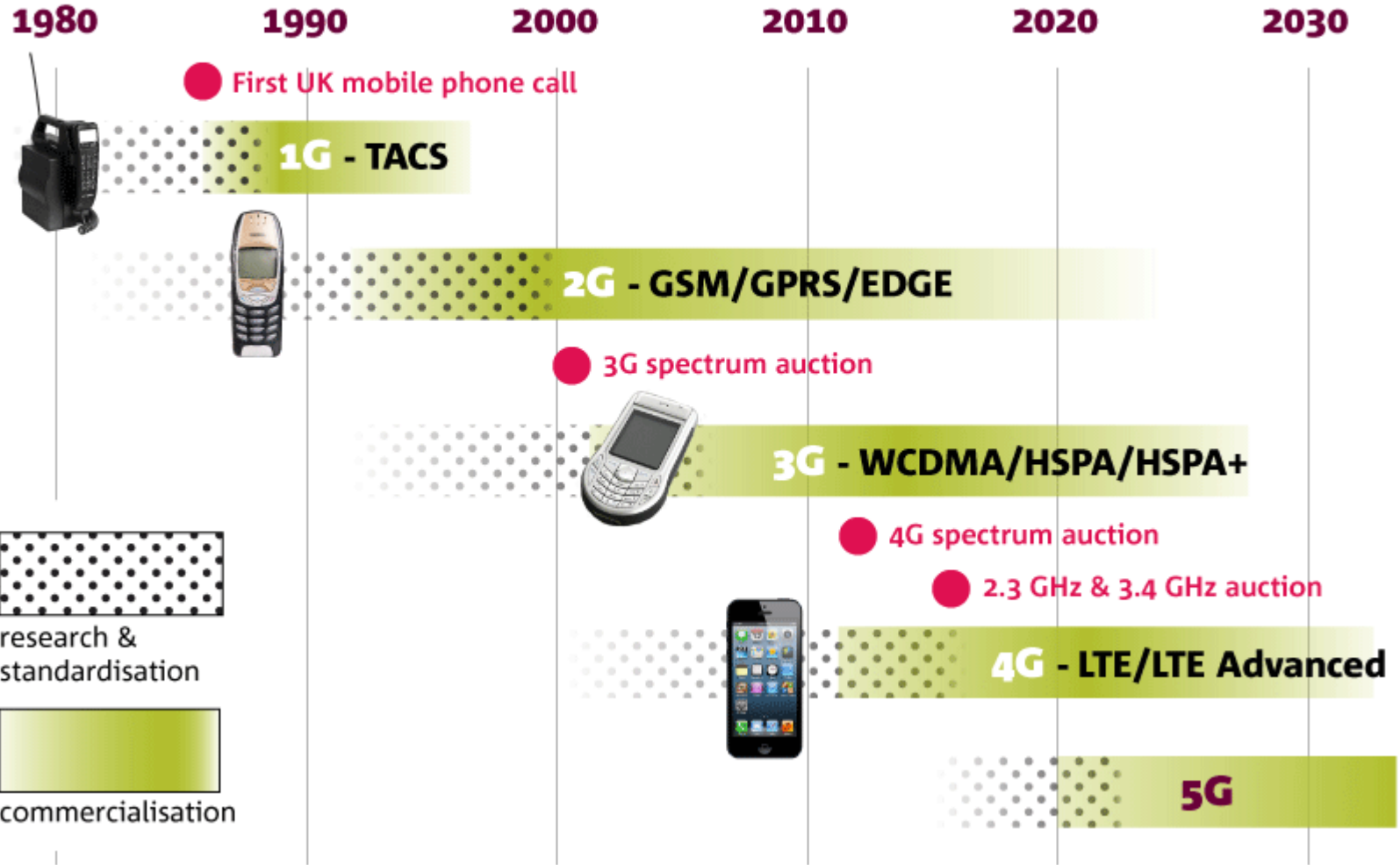



Summary

- 无线局域网的组成
- 802.11的服务
- 802.11的MAC协议： CSMA/CA
 - 与CSMA/CD作比较
- 三种优先级
- 点协同功能和分布式协同功能
- 解决隐藏终端问题
- 802.11的帧类型和帧格式
 - 与以太网帧格式比较